

Detail Z

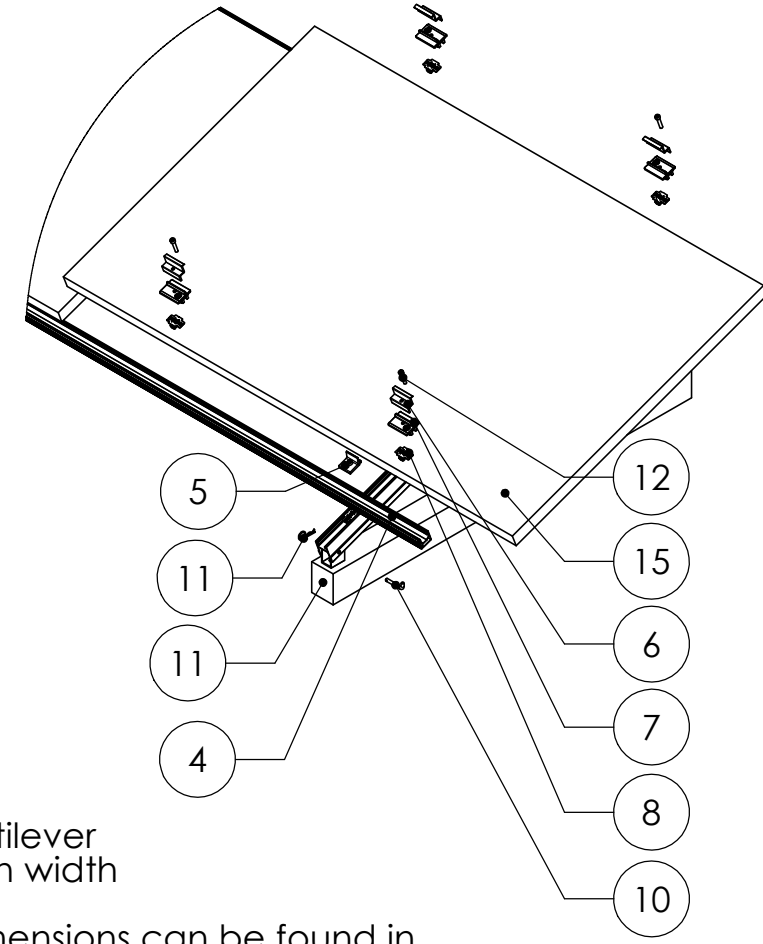

k = cantilever
e = span width

the dimensions can be found in the static report for your project

Detail Y
1:5

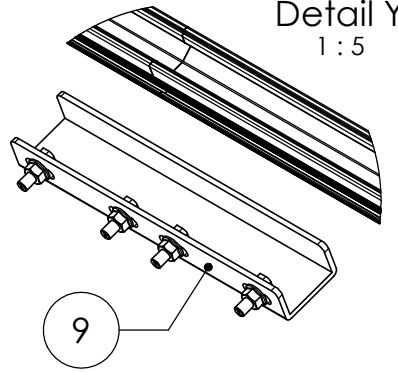

Layout sample
1:50

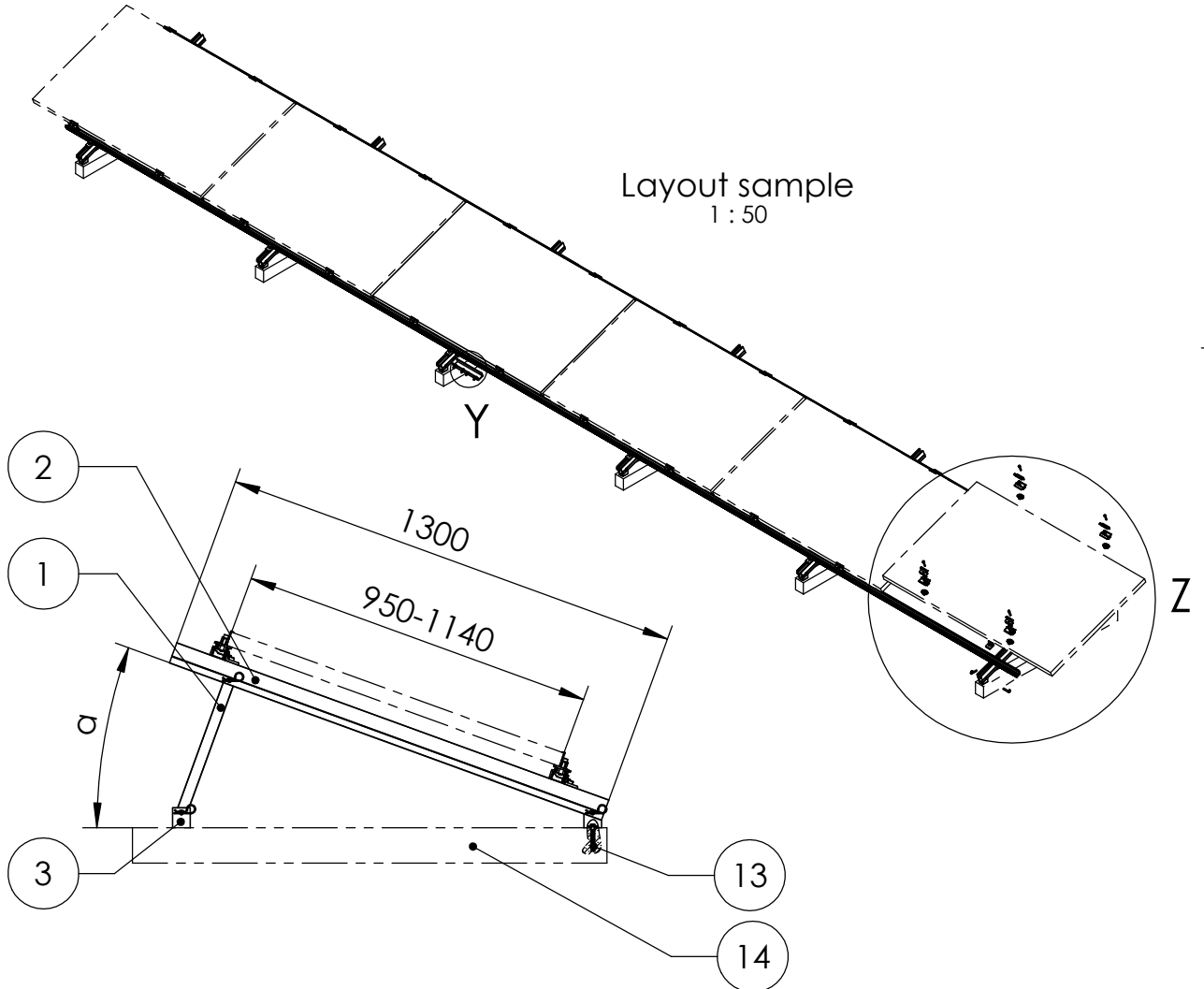

Pos.No.	Designation
2	TiltUp Vento Beam 1300
3	TiltUp Vento Foot
4	SingleRail 36/50
5	Climber 36/50
6	EndClamp Standard
7	AddOn 22/30
8	MK2
9	SingleRail 36/50 Connectot Set
10	TiltUp Vento Pin
11	TiltUp Vento Clip

Pos.No.	Designation	Angle α	Length (mm)
1	TiltUp Vento Brace	20°	446
		25°	558
		30°	679

12	Socket head bolt serrated - sim. ISO 4762 - M8x25
13	MultiMonti 7,5x60
14	Beton
15	Modul



K2 Systems GmbH
Industriestr. 18
71272 Renningen
Germany
+49 7159 42059-0

Designation: **System data sheet
TiltUp Vento Landscape
+ AddOn**

Name	Date	Material:	Item no.:	A3
Designed A. Gerstenberger	03.01.2022	-	---	All dimensions in mm Sheet 1 of 2
Approved J. Sen	17.01.2022	Surface: -	Drawing no.: 07-283-00	
Last change		Weight: -	Scale: 1:20	

This drawing is the sole property of K2 Systems GmbH. It is protected by copyright and may only be copied, reproduced or distributed to a third party with explicit permission!

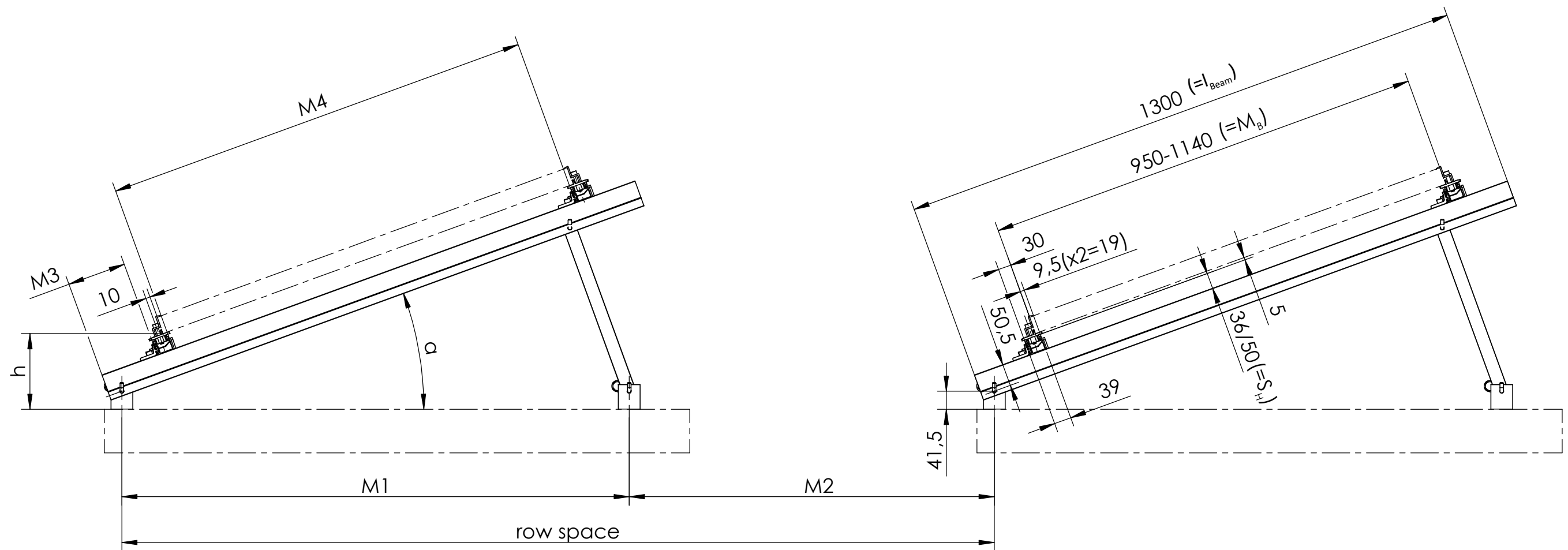

$$h_{def} = 41,5 + (0,5 * l_{Beam} - 30) * \sin(\alpha) + (50,5 + 36 + 5) * \cos(\alpha) - 0,5 * M_B * \sin(\alpha)$$

$$h_{max} = 41,5 + (l_{Beam} - 30 - 0,5 * 39 - 10) * \sin(\alpha) + (50,5 + 36 + 5) * \cos(\alpha) - M_B * \sin(\alpha)$$

Angle α	20°	25°	30°
$h_{min} (M3 \geq 0)$	128	125	121
M1	1164	1207	1262
M2	row space - M1		
M3	$\frac{h_{neu} - (S_H + 50,5 + 5) * \cos(\alpha) - 41,5}{\sin(\alpha)} - 10 + 30 - 39/2$		
M4	$M_B - 19$		
row space min-max	1730-2080	1790-2150	1770-2130



K2 Systems GmbH
 Industriestr. 18
 71272 Renningen
 Germany
 +49 7159 42059-0

Designation:
System data sheet
 TiltUp Vento Landscape + AddOn
 AssemblyDimension

Name	Date	Material:	Item no.:	A3
Designed A. Gerstenberger	03.01.2022	-	---	
Approved J. Sen	17.01.2022	Surface: -	Drawing no.: 07-283-00	All dimensions in mm
Last change		Weight: -	Scale: 1:10	Sheet 2 of 2

This drawing is the sole property of K2 Systems GmbH. It is protected by copyright and may only be copied, reproduced or distributed to a third party with explicit permission!