

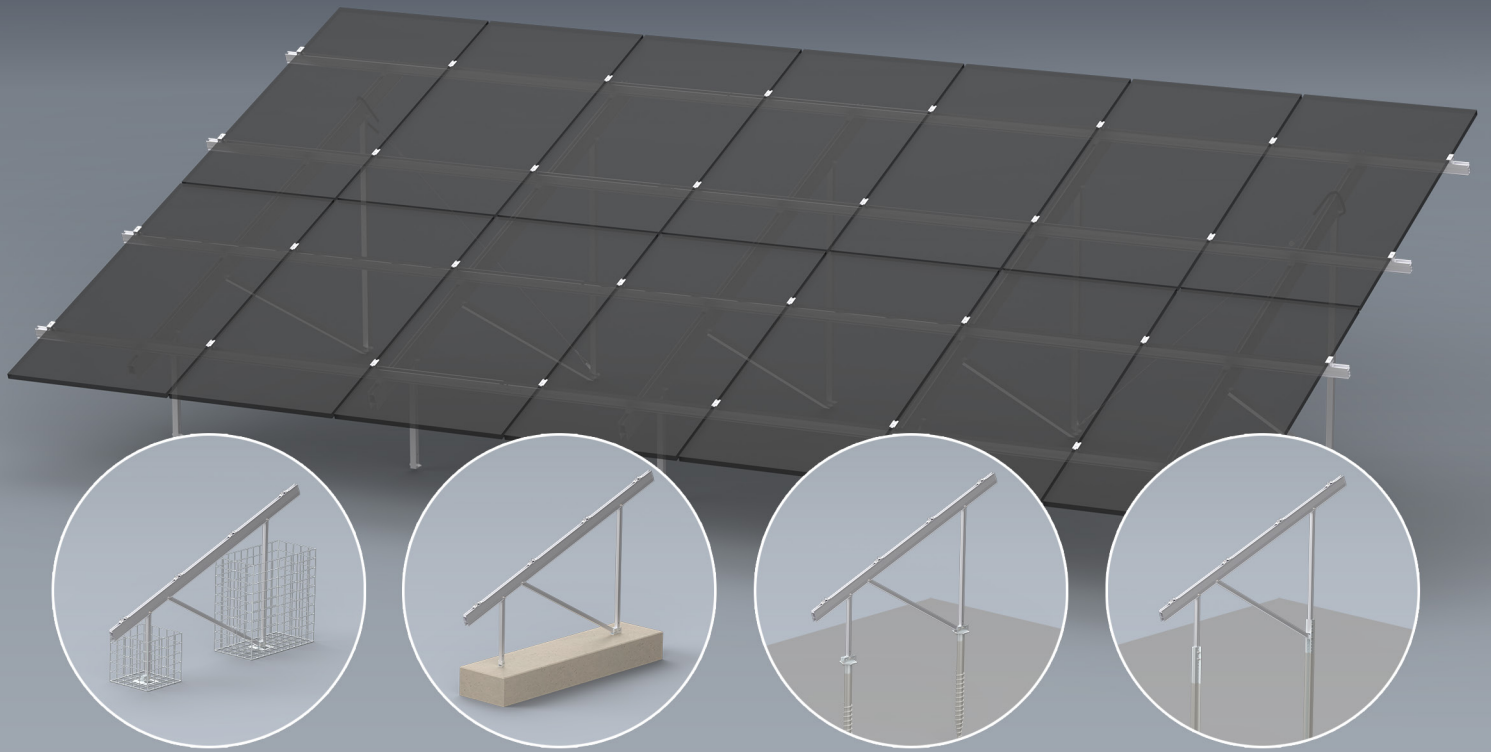

Connecting Strength



 Assembly instructions

N-Rack Kit

Gabions, Concrete, Ground Screws
and Pile-driven Foundations

Content

Main tools	3	Ground screw foundations	26
		• General guidelines	26
General safety information	4	• Additional tools	26
		• Components	27
The following guidelines apply	5	• Installation	28
• Important assembly instructions	5	• Foundation work and spacing	28
• Static information	5	• Connecting supports	29
Overview of the main components	6	Pile-driven foundations	30
• N-Rack Top Kits	6	• General guidelines	30
• N-Rack Ground Kits	6	• Additional tools	30
• Gabions	6	• Components	31
• Concrete foundations	6	• Installation	32
• Ground Screw foundations	7	• Foundation work	32
• Pile-driven foundations	7	• Spacing	32
		• Connecting supports	33
List of articles	8	8 Installing mounting rails and modules	34
• N-Rack Top Kits	8	• Components from the N-Rack Top Kit	34
• Small parts	9	• Installation	35
• N-Rack Ground Kits	10	• Connecting the CrossRail mounting rail	36
• Gabion	10	• Module installation	36
• Concrete	10		
• Ground screw	11		
• Pile	11	Setting up wind bracing	38
Pre-assembly of module supports	12		
• Components from the N-Rack Top Kit and N-Rack Ground Kit	12		
• Supports	13		
Gabions	14		
• General guidelines	14		
• Additional tools	14		
• Components	15		
• Installation	16		
• Preparing gabions	16		
• Spacing	16		
• Positioning gabions	17		
• Connecting supports	18		
• Adding bulk material	19		
Concrete foundations	20		
• General guidelines	20		
• Additional tools	20		
• Components	21		
• Installation	22		
• Dimensions	22		
• Spacing	22		
• Pre-drilled anchor holes	23		
• Fixing the anchors and connection	23		
• Connecting supports	24		

Main tools

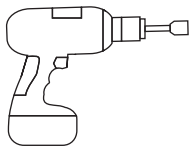

6 mm



8 mm

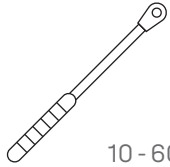

10 - 60 Nm
(7.4 - 44.2 lb-ft)



6 mm



16, 17, 18, 19 mm

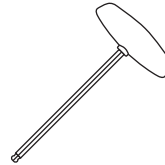

6 mm



16, 17, 18, 19 mm

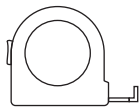

≥ 3.0 m

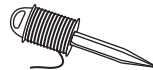

Quality tested - several certifications

K2 Systems stands for secure connections, highest quality and precision. Our customers and business partners have known that for a long time. Independent institutes have tested, confirmed and certified our capabilities and components.

Please find our quality and product certificates under:

k2-systems.com.

General safety information

Please note that our general mounting instructions must be followed at all times and can be viewed online at [k2-systems.com](https://www.k2-systems.com)

- The equipment may only be installed and operated by qualified and adequately trained installers.
- Prior to installation, ensure that the product complies with on-site static loading requirements. For roof-mounted systems, the roof load-bearing capacity must always be checked.
- National and local building regulations and environmental requirements must be adhered to.
- Compliance with health and safety regulations, accident prevention guidelines and applicable standards is required.
 - Protective equipment such as safety helmet, boots and gloves must be worn.
 - Roofing works must be in accordance with roofing regulations utilising fall protection safeguards when eaves height exceeds 3 m.
 - At least two people must be present for the duration of the installation work in order to provide rapid assistance in the event of an emergency.
- K2 mounting systems are continuously developed and improved and the installation process may thereby change at any time. Prior to installation consult our website at www.k2-systems.com/en/technical-information for up-to-date instructions. We can send you the latest version on request.
- The assembly instructions of the module manufacturer must be adhered to.
- Equipotential bonding/grounding/earthing between individual parts is to be performed according to country specific standards, as well as national laws and regulations.
- At least one copy of the assembly instructions should be available on site throughout the duration of the installation.
- Failure to adhere to our general safety and assembly instructions and not using all system components, K2 is not liable for any resulting defects or damages. We do not accept liability for any damage resulting in the use of competitor's parts. Warranty is excluded in such cases.
- K2 Systems GmbH reserves the right to exclude liability in case of disregard of our General Safety Instructions as well as in case of installation or mounting of components of a competitor.
- If all safety instructions are adhered to and the system is correctly installed, there is a product warranty entitlement of 12 years! We strongly recommend reviewing our terms of guarantee, which can be viewed at [k2-systems.com/en/warranty-terms-and-conditions](https://www.k2-systems.com/en/warranty-terms-and-conditions) We will also send this information on request.
- Dismantling of the system is performed in reverse order to the assembly.
- K2 stainless steel components are available in different corrosion resistance classes. Each structure or component must be carefully checked for possible corrosion exposure.

The following guidelines apply

This system can be used without further testing by K2 systems under the following standard conditions. It is also suitable for higher requirements, however if a value exceeds the standard conditions, please contact K2 Systems.



Important assembly instructions



- The general standards and regulations for lightning protection must be observed on site and, where appropriate, a specialist must be consulted in order to draw up a lightning protection concept (use a lightning protection clamp if necessary). Country-specific regulations must be observed.
- Observe the permissible clamping range according to the module manufacturers installation manuals.
- Module frame heights: 25 - 40 mm



Static information

Different static specifications apply depending on the foundations of the N-Rack Kits. This information can be found in the respective section:

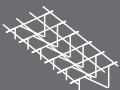
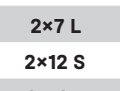
- Gabions Page 14
- Concrete foundations Page 20
- Ground Screw foundations Page 26
- Pile-driven foundations Page 30

N-Rack Top Kit	Number of modules	Module sizes		Permissible loads		Lifting support forces	Vertical support forces	Horizontal support forces
		Length [mm]	Width [mm]	Peak velocity pressure $q_p(z)$ kN/m ²	Snow load on ground level s_k kN/m ²	kN	kN	kN
	14	1,722 - 1,905	≤ 1,150	0.67	1.75	-6.27	12.17	0.97
	14	1,906 - 2,384	≤ 1,150	0.67	1.75	-6.29	11.92	0.96
	24	1,722 - 1,905	≤ 1,150	0.67	1.75	-7.03	13.63	1.09
	24	1,906 - 2,384	≤ 1,150	0.67	1.75	-6.66	12.63	1.02

Overview of the main components

N-Rack Top Kits

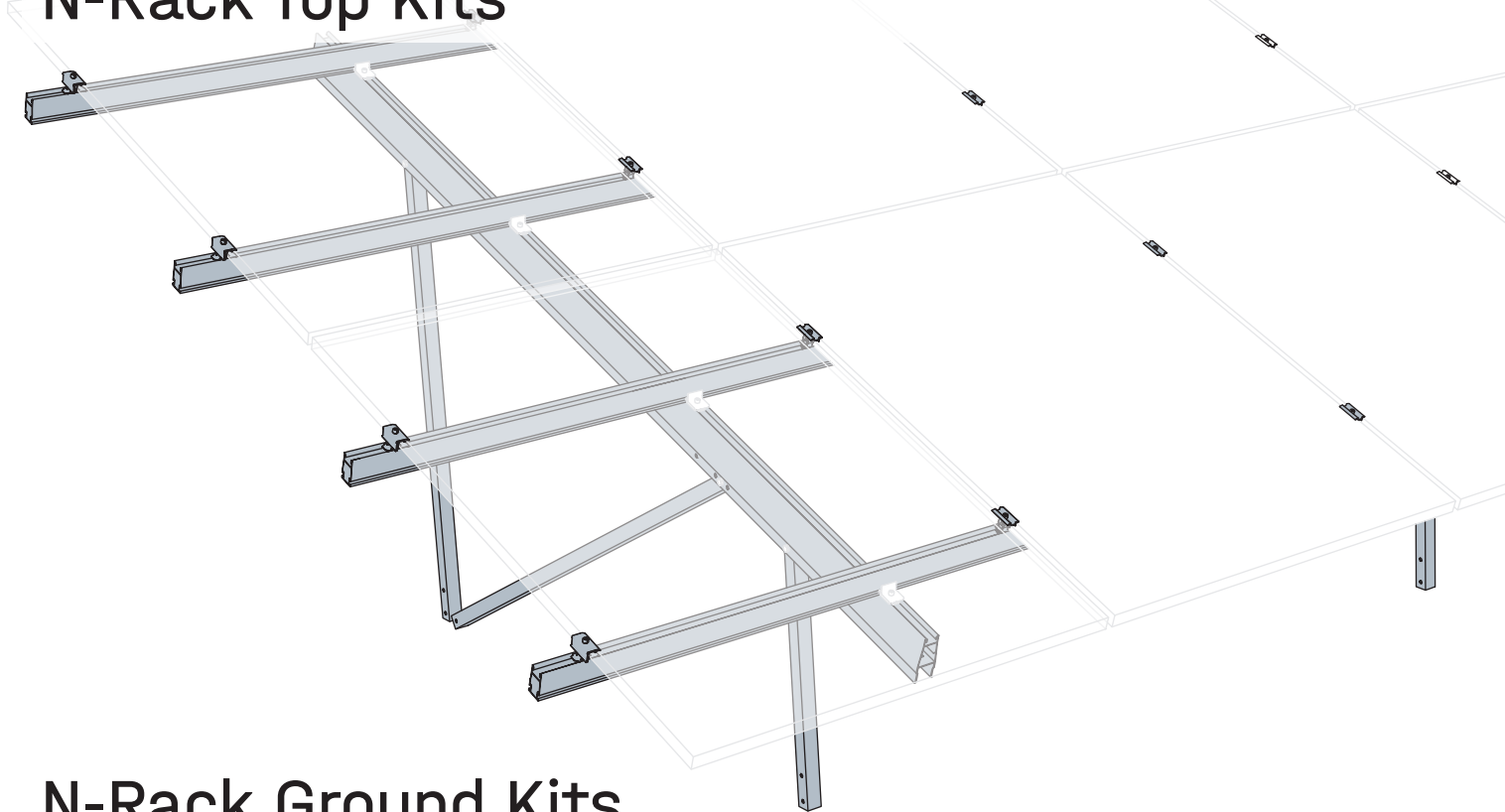

N-Rack Ground Kits

Gabions

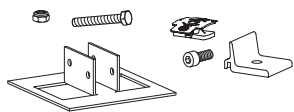
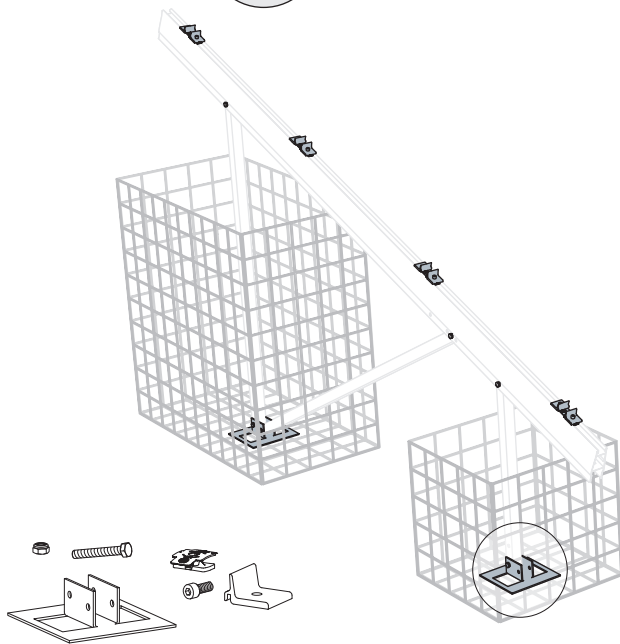
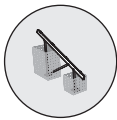

2005110
N-Rack Ground Kit Gabion
See page 14!

Note: Gabions have to be sourced separately.

Concrete foundations

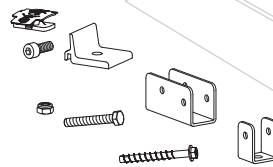
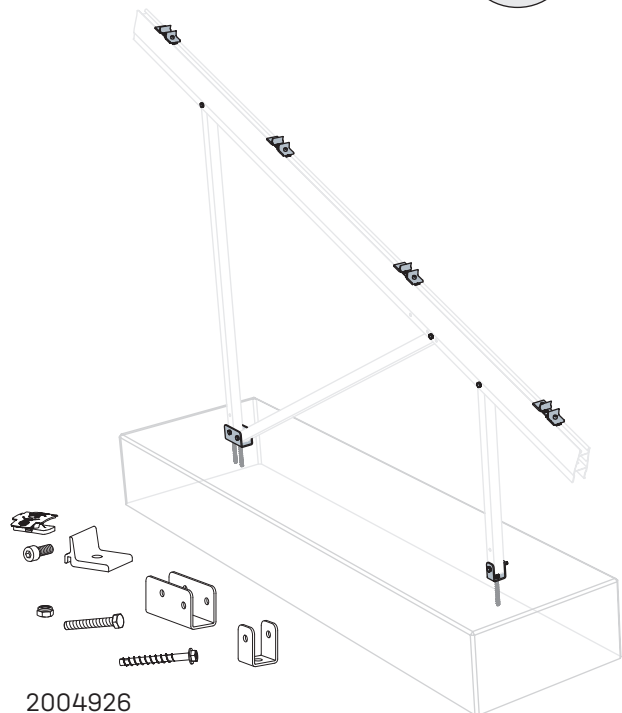
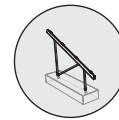

2004926
N-Rack Ground Kit Concrete
See page 20!

Note: Concrete foundations have to be sourced separately.

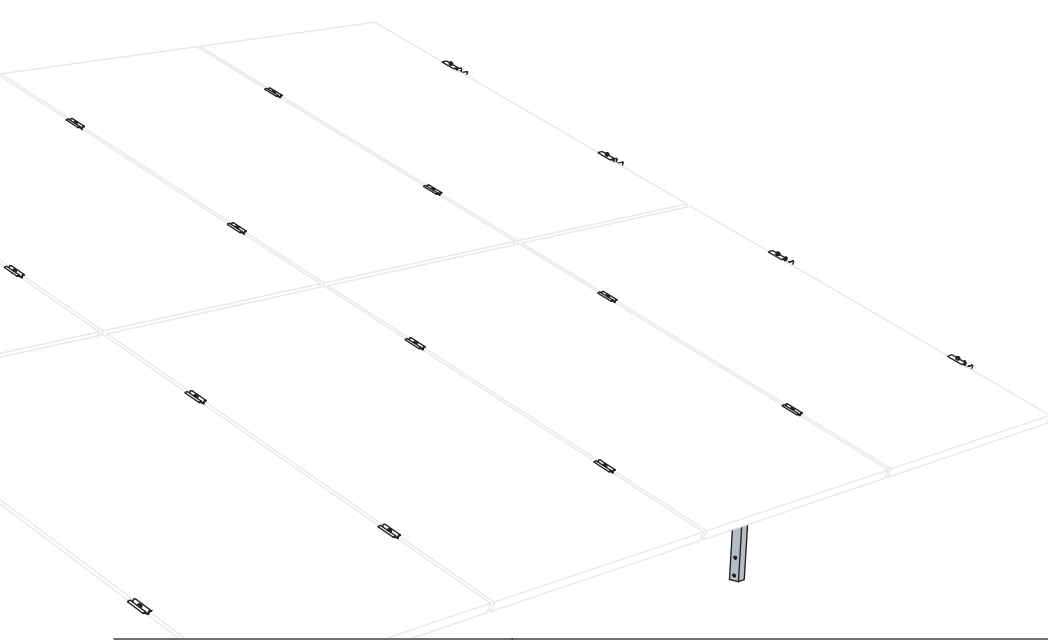

N-Rack Ground Kit		N-Rack Top Kit			
		2×7		2×12	
Module lengths S: 1,722 - 1,905 mm L: 1,906 - 2,384 mm Module widths S/L: ≤1,150 mm		S	L	S	L
		1× 2004925	1× 2004924	1× 2005048	1× 2005047
Foundation type	Article no.	Required quantity of N-Rack Ground Kits per N-Rack Top Kit			
Gabions	2005110	4×	5×	6×	8×
Concrete foundations	2004926				
Ground Screw foundations	2004927				
Pile-driven foundations	2005113				

Ground Screw foundations



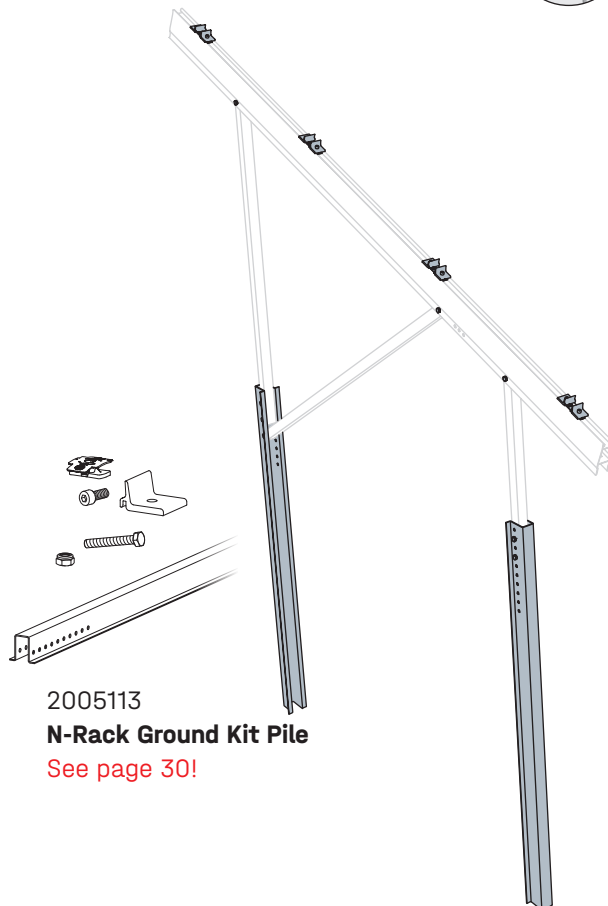
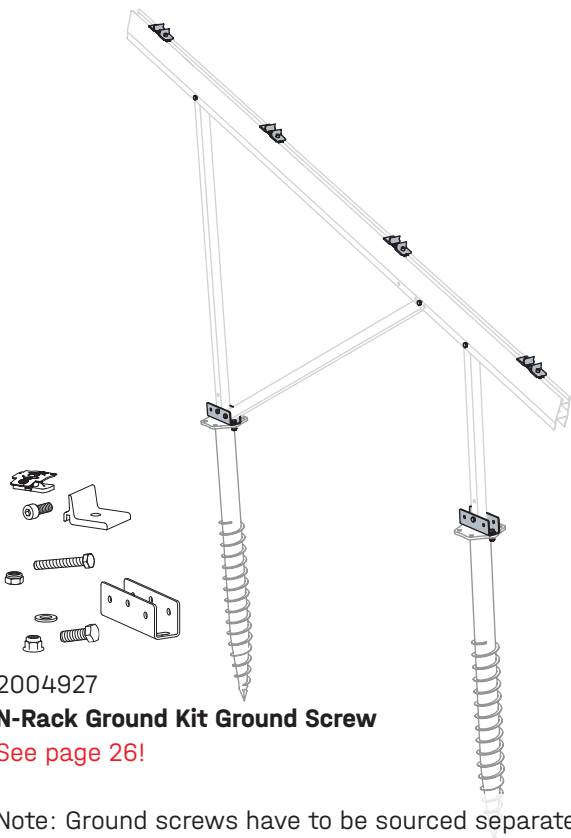

Pile-driven foundations



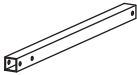
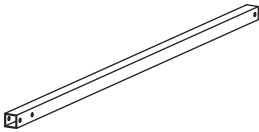
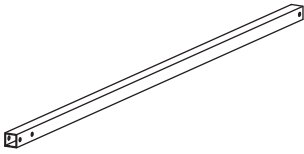
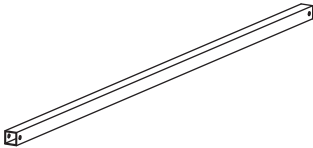
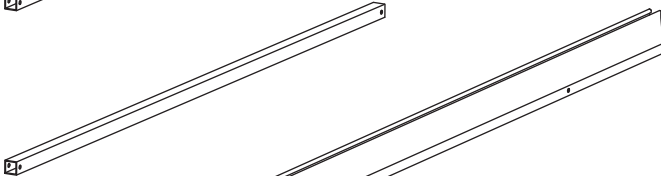
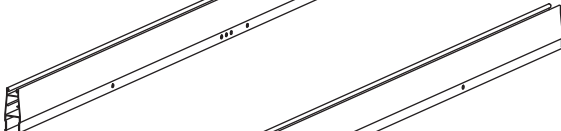
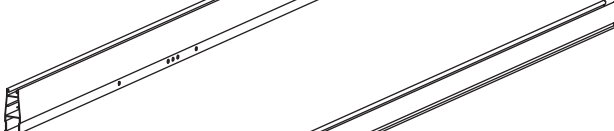
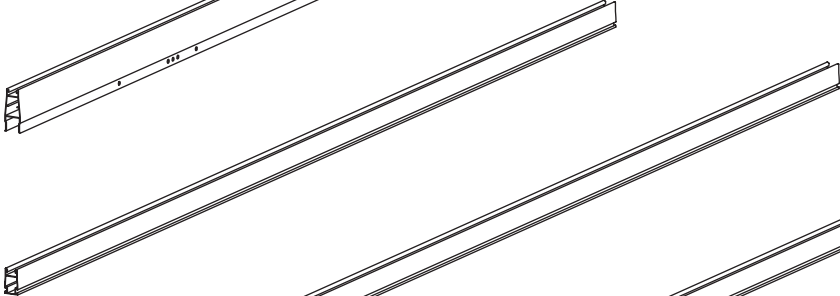
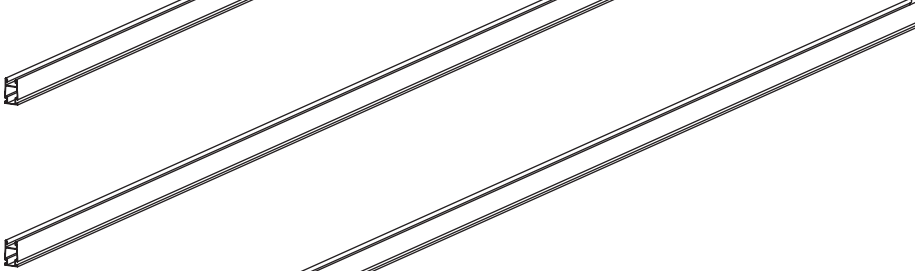

Note: Ground screws have to be sourced separately.

List of articles

N-Rack Top Kits

Article quantity				Article	
2x7		2x12			
S	L	S	L		
4x	5x	6x	8x	2004401 3-Hole Brace N-Rack 715	
4x		6x		2004402 3-Hole Brace N-Rack 1370	
	5x	8x		2004403 3-Hole Brace N-Rack 1625	
4x		6x		2004404 2-Hole Brace N-Rack 1696	
	5x	8x		2004411 2-Hole Brace N-Rack 2072	
	5x	8x		2004399 Beam N-Rack 3750	
4x		6x		2004400 Beam N-Rack 3020	
4x	4x			2005064 CrossRail 73 3.3 m	
		8x	8x	2004460 CrossRail 73 4.55 m	
4x	4x	4x	4x	2004461 CrossRail 73 5 m	

Small parts

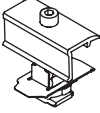
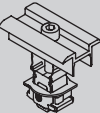
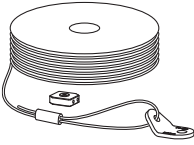
Article quantity				Article	
2×7		2×12			
S	L	S	L		
4×	4×	8×	8×	2004409 CrossRail 73 Connector	
20×	20×	40×	40×	1001051 Drilling Screw 5.5 × 25 A2	
8×	8×	8×	8×	2004543 K2 Clamp EC 25 - 40	
24×	24×	44×	44×	2004146 K2 Clamp MC 25 - 40	
2×	2×	2×	2×	2004410 Wind Bracing Set	

N-Rack Ground Kits

Gabion

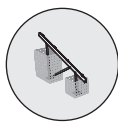

Article quantity	Article	
2×	2005109 N-Rack Gabion Foot	
7×	2004408 Hexagon Head Screw M10 × 70	
7×	1002849 Hexagon Locking Nut M10	
8×	2003145 Climber 36/50 Set	



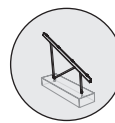



Concrete

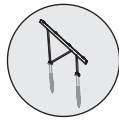

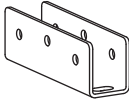
Article quantity	Article	
1×	2004391 N-Rack Foot Front	
1×	2004392 N-Rack Foot Back	
3×	2004407 Heco Multi-Monti 12 × 105	
7×	2004408 Hexagon Head Screw M10 × 70	
7×	1002849 Hexagon Locking Nut M10	
8×	2003145 Climber 36/50 Set	



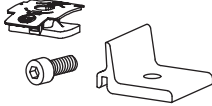

Ground screw

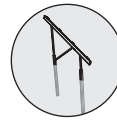

Article quantity	Article	
2×	2004896 N-Rack GS Foot	
4×	2004902 Hexagon Head Screw M12 × 35	
4×	2004910 Washer M12	
4×	2004903 Hexagon Nut M12	
9×	2004408 Hexagon Head Screw M10 × 70	
9×	1002849 Hexagon Lock- ing Nut M10	
8×	82003145 Climber 36/50 Set	

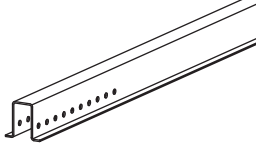
Pile



Article quantity	Article	
2×	2005112 Cap Profile N-Rack 2,3 m	
7×	2004408 Hexagon Head Screw M10 × 70	
7×	1002849 Hexagon Lock- ing Nut M10	
8×	2003145 Climber 36/50 Set	

Pre-assembly of module supports

Components from the N-Rack Top Kit and N-Rack Ground Kit

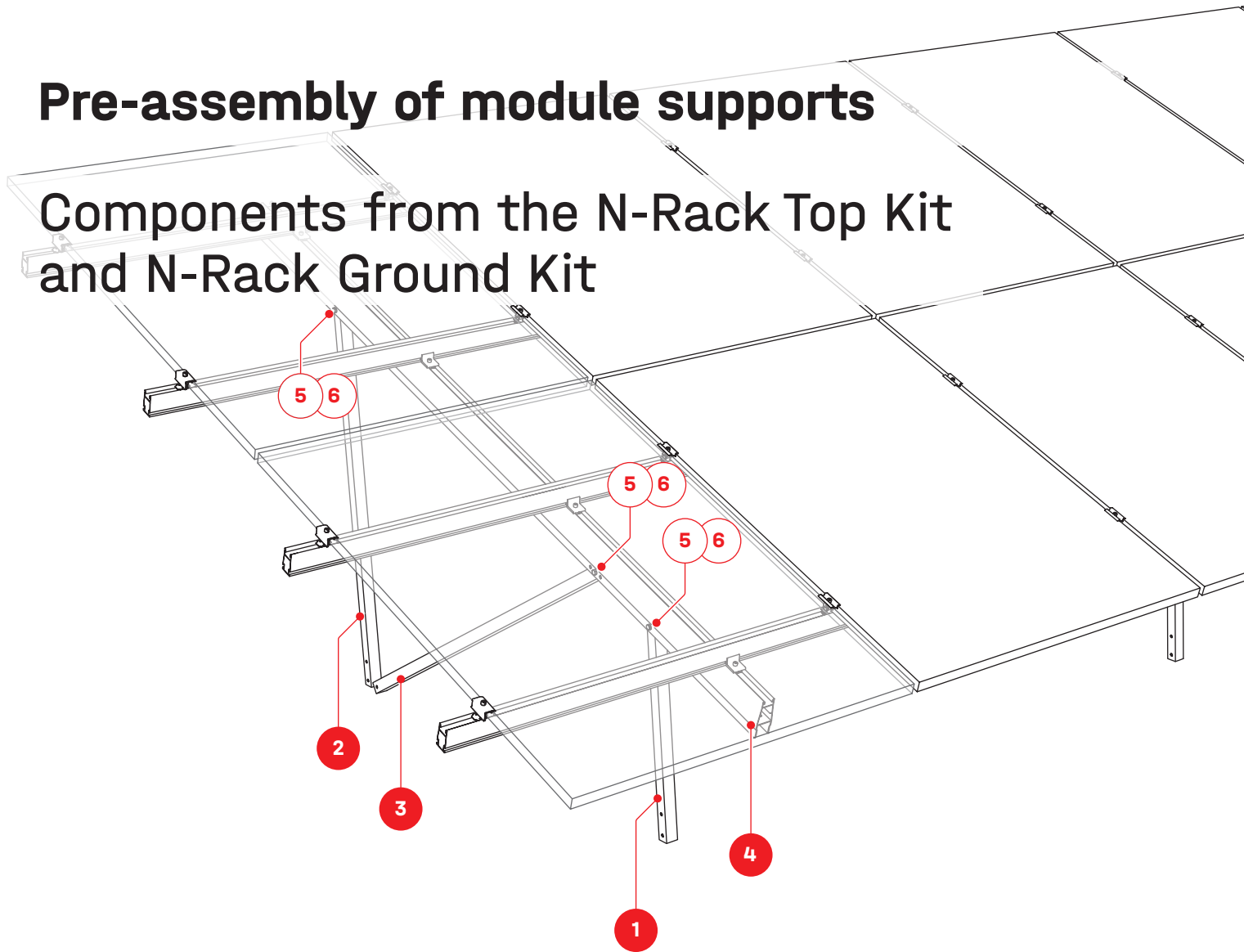

N-Rack Top Kit

1 3-Hole Brace N-Rack

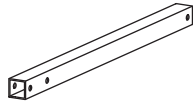

2 3-Hole Brace N-Rack

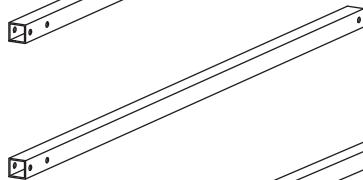

3 2-Hole Brace N-Rack

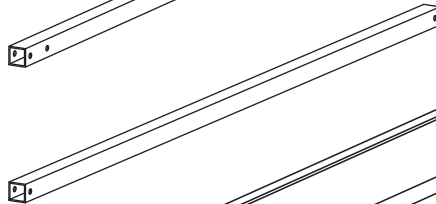

4 Beam N-Rack

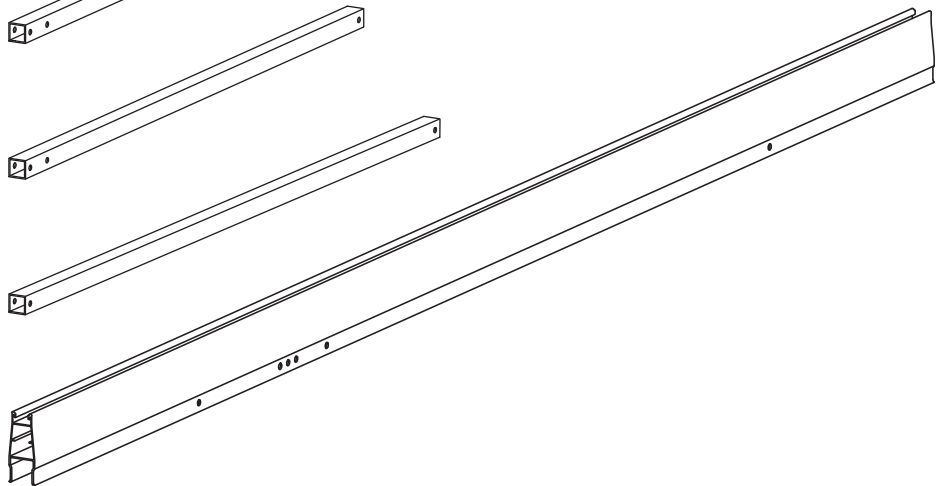

N-Rack Ground Kit

5 Hexagon Head Screw with Shank M10 x 70



6 Hexagon Locking Nut M10



Supports

1

! Tighten screws only by hand.

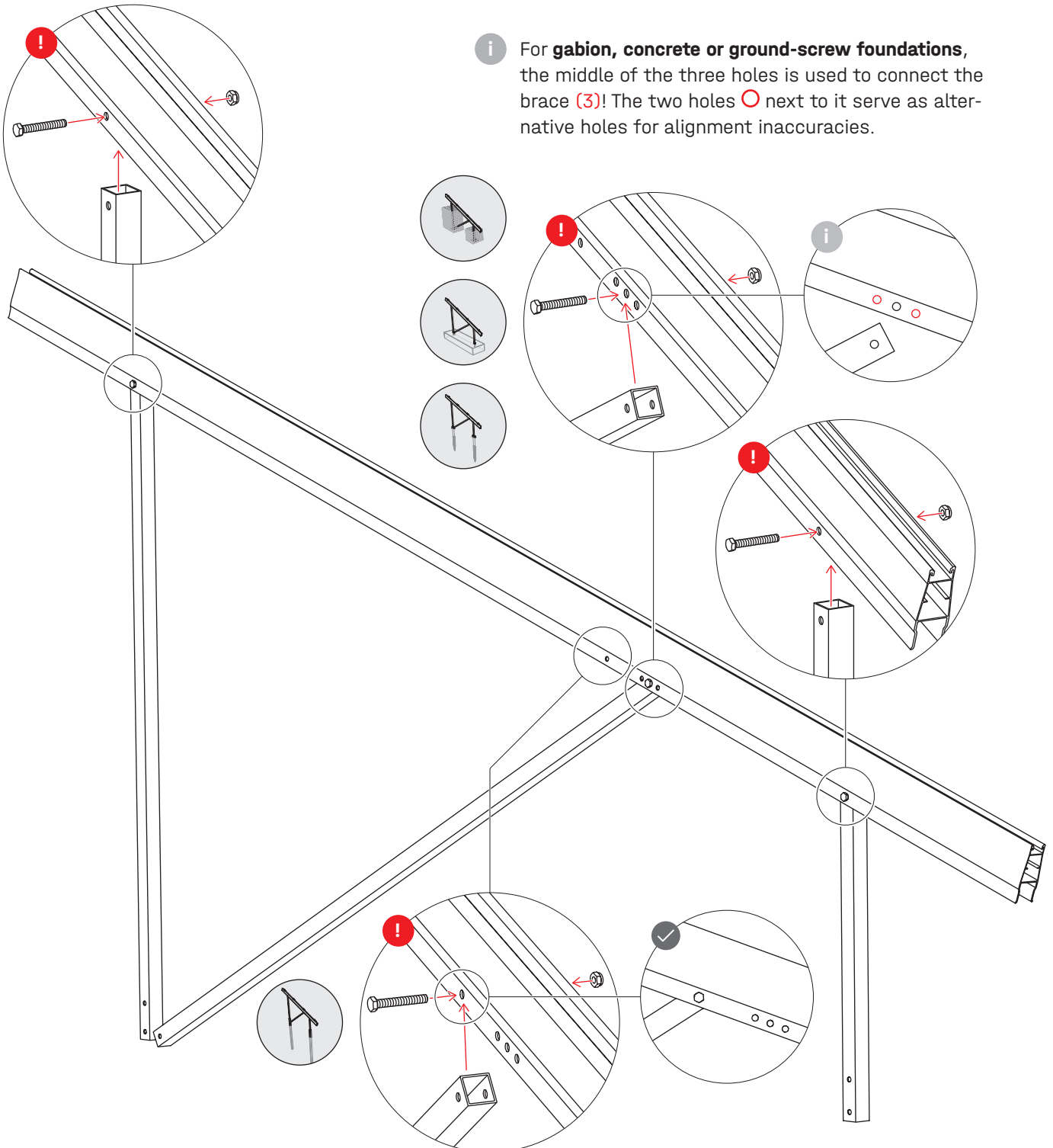

i For **gabion, concrete or ground-screw foundations**, the middle of the three holes is used to connect the brace (3)! The two holes ○ next to it serve as alternative holes for alignment inaccuracies.

For **pile-driven foundations**, the brace (3) must be connected to the individual hole!

Gabions

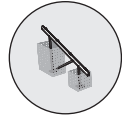

General guidelines





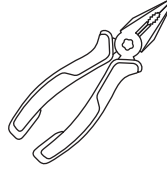

Soil requirements

The substrate must be compressed and non-skid in accordance with the recognised rules of engineering (in particular: DIN EN 1997-1-Eurocode7-Geotechnical Design) to guarantee the permanent positional safety of the structure.

Additional tools

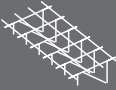

Structural requirements

N-Rack Top Kit	Number of modules	Filling weight	
		kg	kg
			
2×7 S	14	220	700
2×7 L	14	230	700
2×12 S	24	240	790
2×12 L	24	240	740

Important notes

Gabions shall be filled with stones / aggregate that is frost- & weather-resistant, sufficiently pressure-resistant and has minimal voids.

The information from the gabion manufacturer must be observed

The assembly instructions for the gabions (item no. 2005184 Gabion 50×50×50 and item no. 2005185 Gabion 100×50×100) are available here: www.rothfuss-bestgabion.de/wp-content/uploads/2025/02/Assembly-instructions-ROKO-EN.pdf

Components

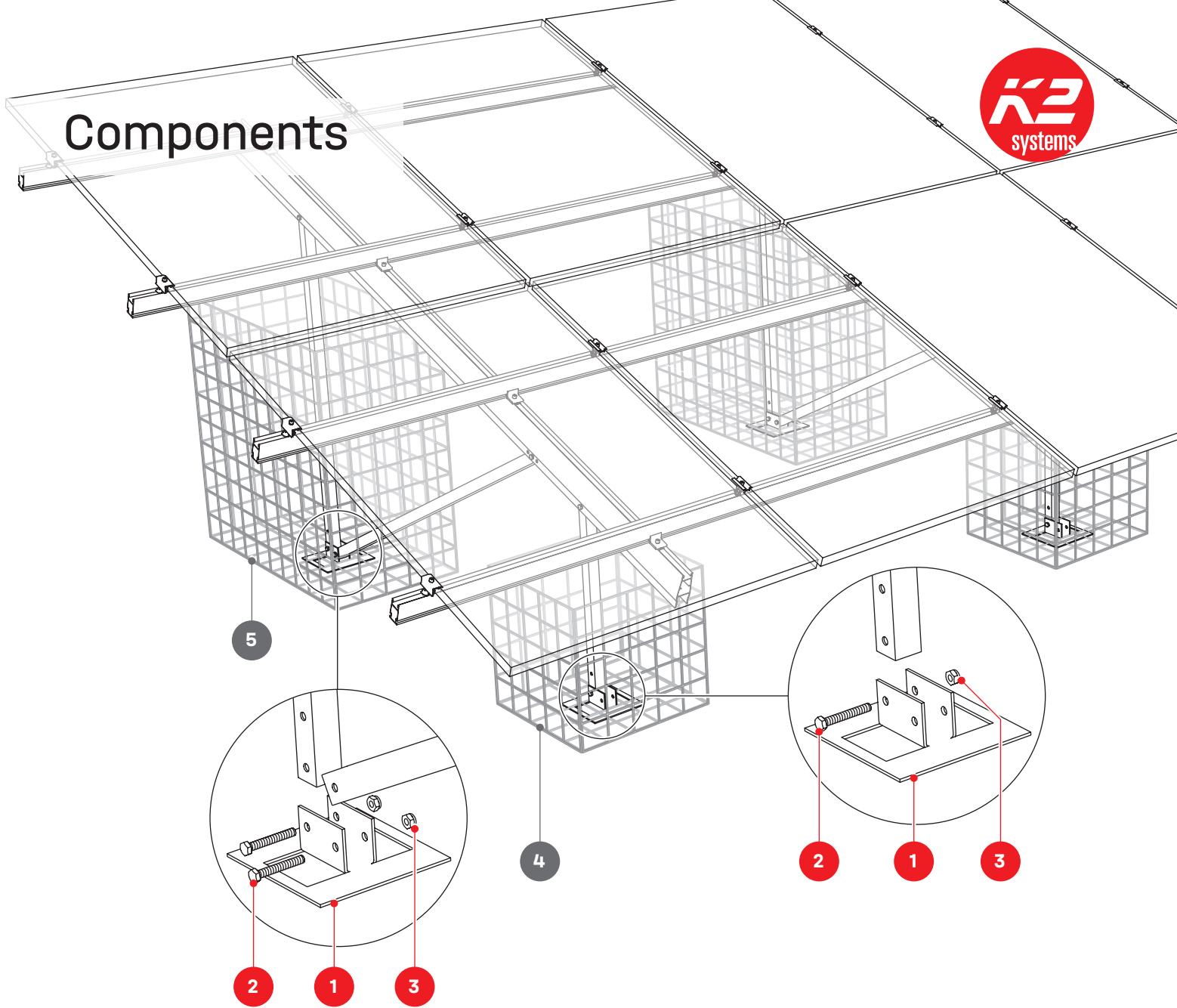

N-Rack Ground Kit Gabion

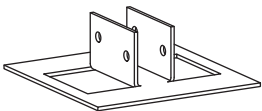

1 2005109
N-Rack Gabion Foot



2 2004408
Hexagon Head Screw
with Shank M10 × 70



3 1002849
Hexagon Locking Nut
M10

Required - not included

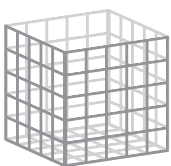

4 2005184
Gabion 50×50×50
To be sourced separately

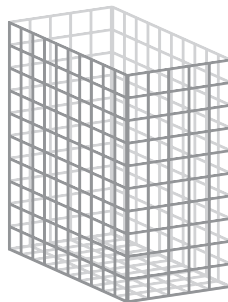

5 2005185
Gabion 100×50×100
To be sourced separately

Installation

Preparing gabions

1a Observe the manufacturer's assembly instructions when setting up the gabions.

The assembly instructions for the gabions (item no. 2005184 Gabion 50×50×50 and item no. 2005185 Gabion 100×50×100) are available here: [Assembly-instructions.pdf](#)

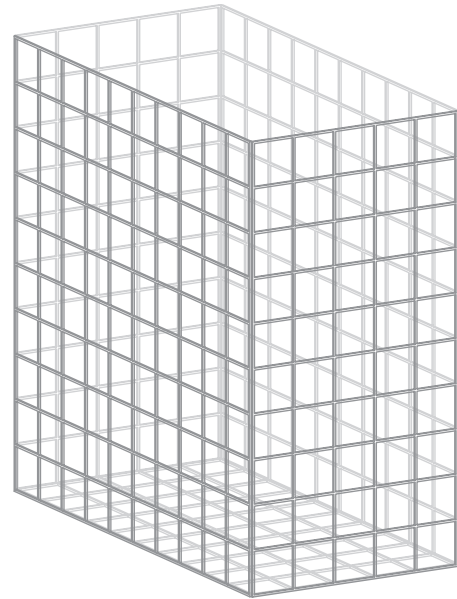
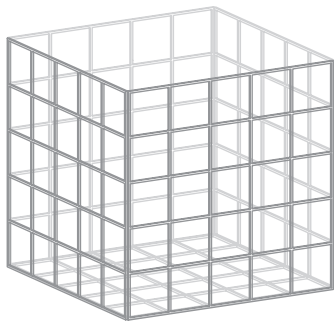

To make it easier to install the support, the rear side mesh should remain open.

Spacing

1b Values e and z in the system data sheets "Gabions" from page 40 onwards.

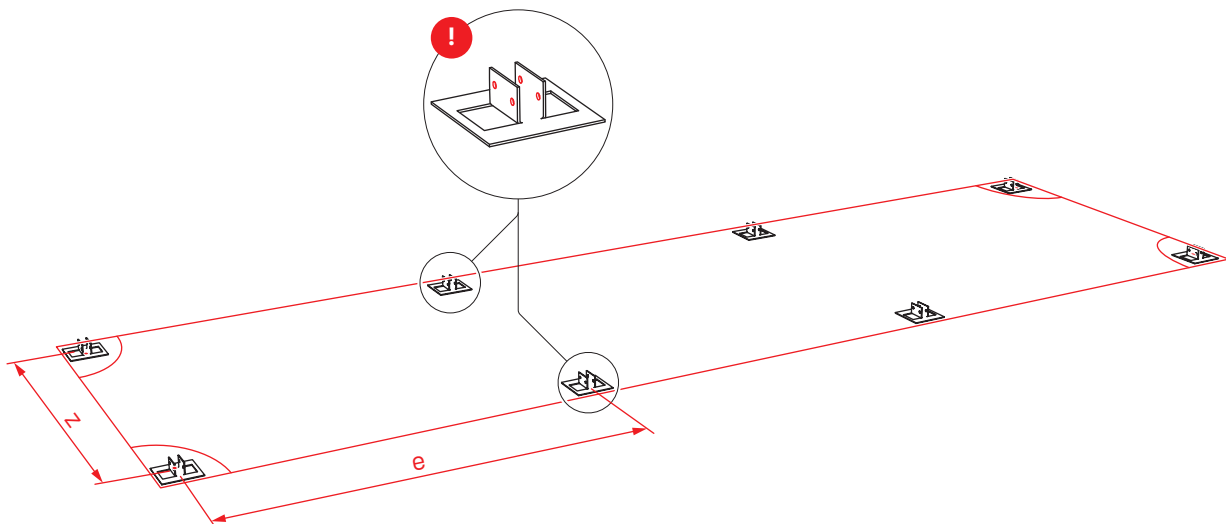

! Observe the alignment of the N-Rack Gabion Foot

Positioning gabions

2a

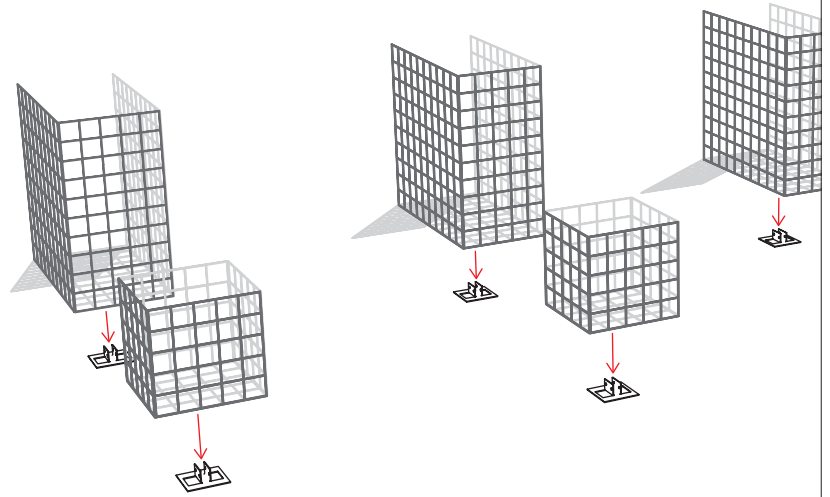
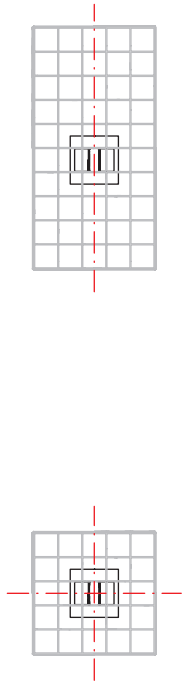

2b

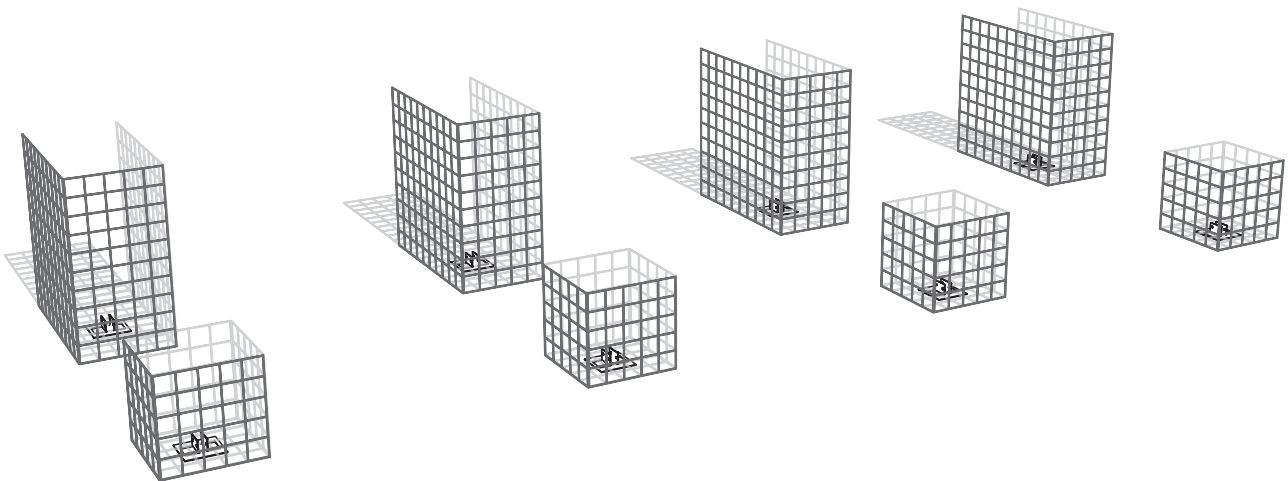

Adding bulk material

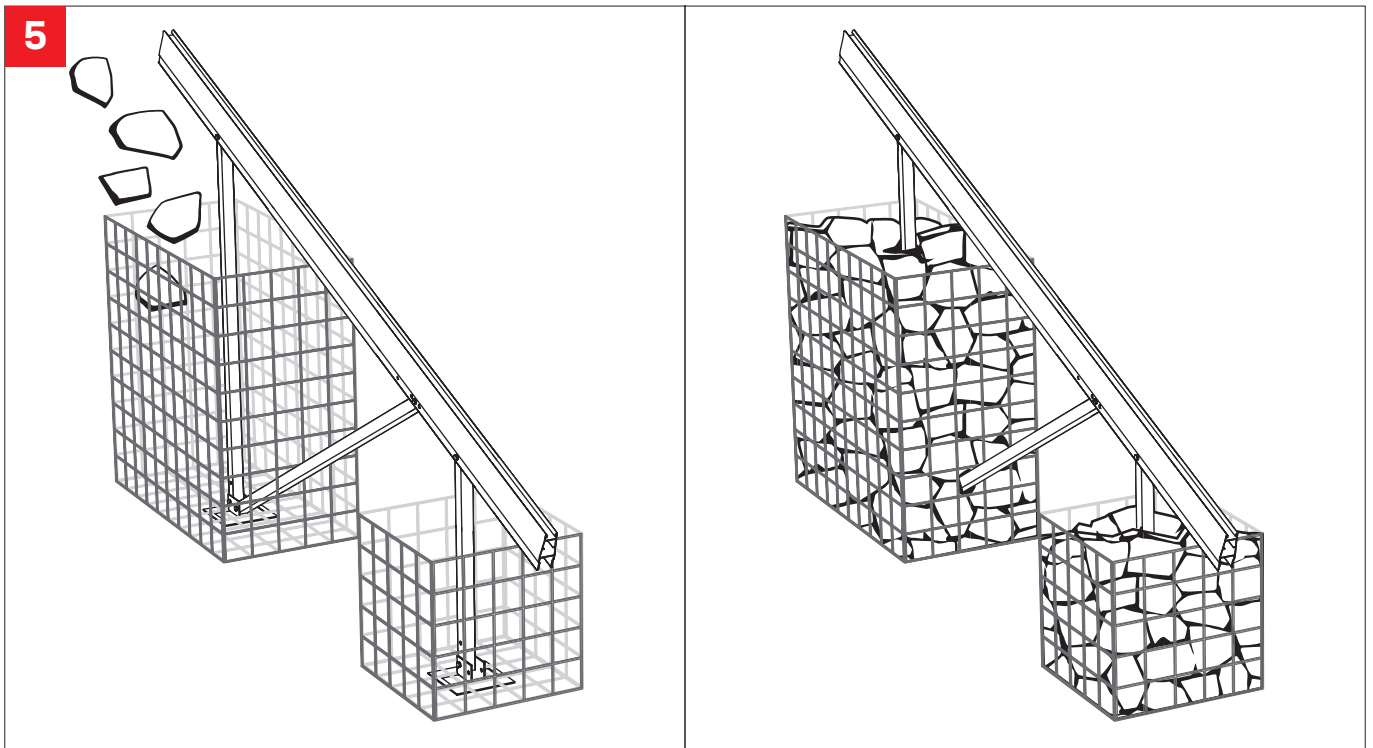

Concrete foundations

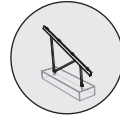

General guidelines



Soil requirements

The substrate must be compressed and non-skid in accordance with the recognised rules of engineering (in particular: DIN EN 1997-1-Eurocode7-Geotechnical Design) to guarantee the permanent positional safety of the structure.

Structural requirements

The concrete foundations are pre-dimensioned to protect against uplift and tilting as a result of the wind loads. Reinforcement of the foundations must be provided as shown in the schematic diagram "Dimensions" on page 22. Determination of the final dimension of the concrete foundations and their reinforcement plan must be checked on site.

Additional tools

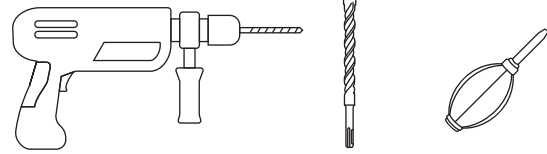

10 mm

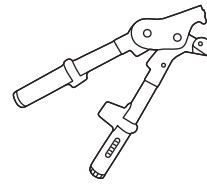

Gripple Collet Chuck 400 · 2004456

Components

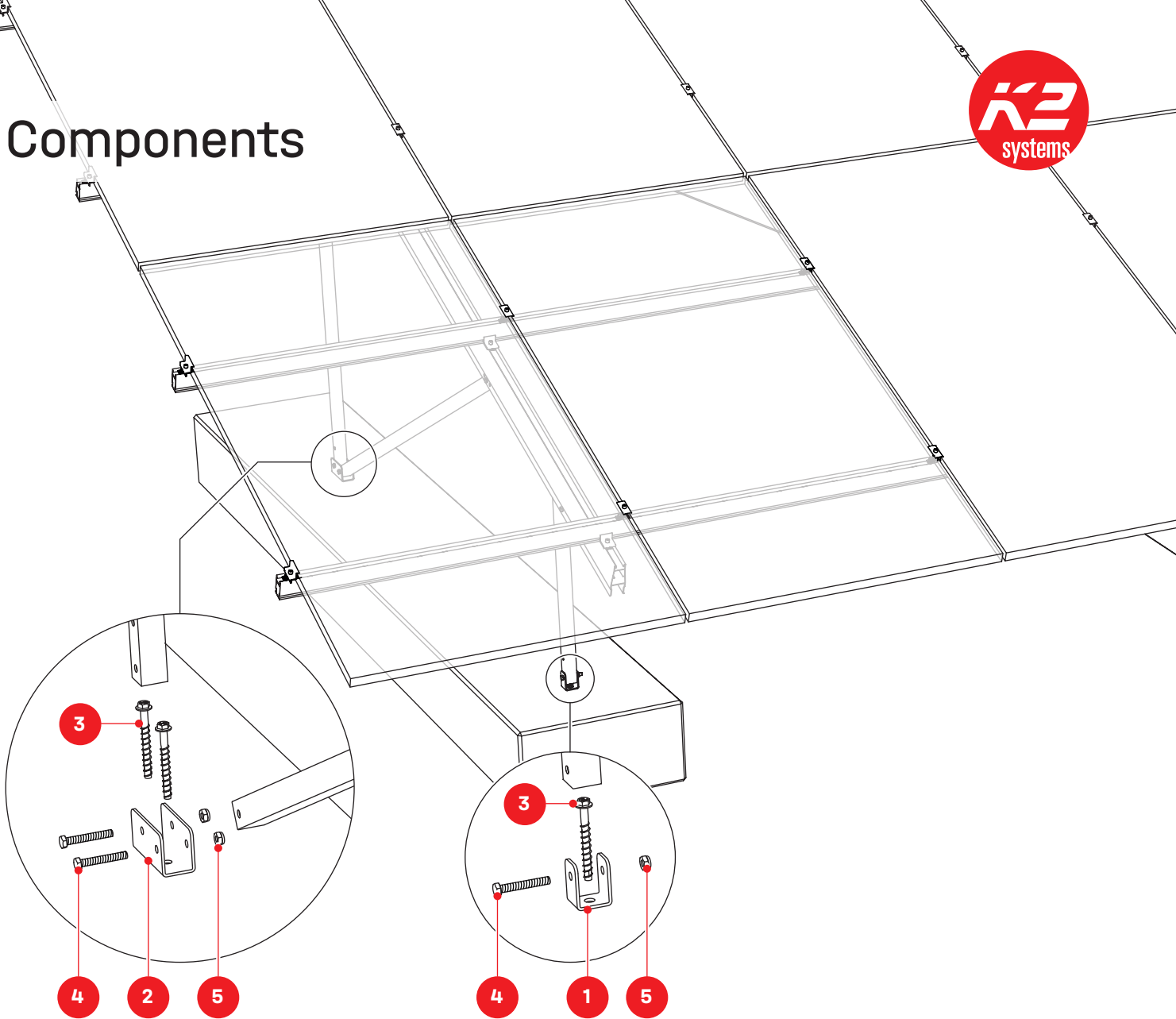

N-Rack Ground Kit Concrete



1 2004391
N-Rack Concrete Foot Front

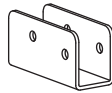

2 2004392
N-Rack Concrete Foot Back



3 2004407
Heco Multi-Monti 12 × 105



4 2004408
Hexagon Head Screw
with Shank M10 × 70



5 1002849
Hexagon Locking Nut
M10

Installation

Dimensions

i The concrete foundations must be sourced separately and build on site.

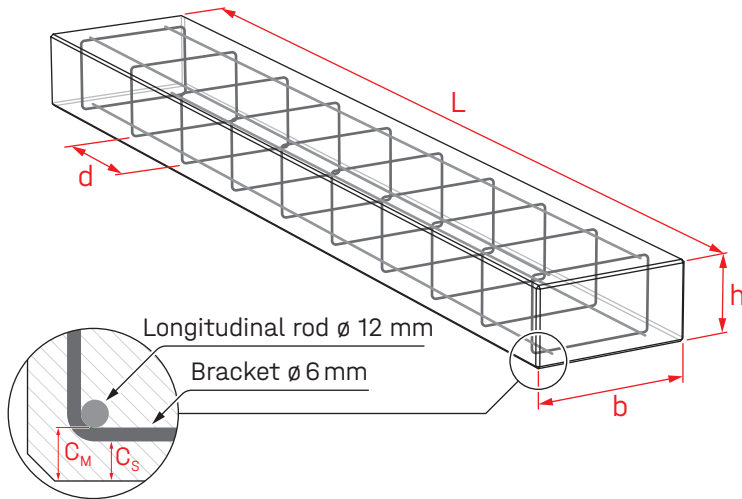

Reinforcing steel: B500
Concrete strength: min. C25/30
Concrete covering of the reinforcement: $C_M/C_S \geq 0.04$ m

N-Rack	2×7 S	2×7 L	2×12 S	2×12 L
L [m]	2.80	3.40	2.80	3.40
w[m]	0.45	0.45	0.78	0.72
h [m]	0.40	0.40	0.40	0.40
V [m³]	0.50	0.61	0.87	0.98
d [m]	0.30	0.30	0.30	0.30
Quantity of brackets	10 ×	12 ×	10 ×	12 ×

Spacing

1 Values e and z in the system data sheets "Concrete foundations" from page 48 onwards.

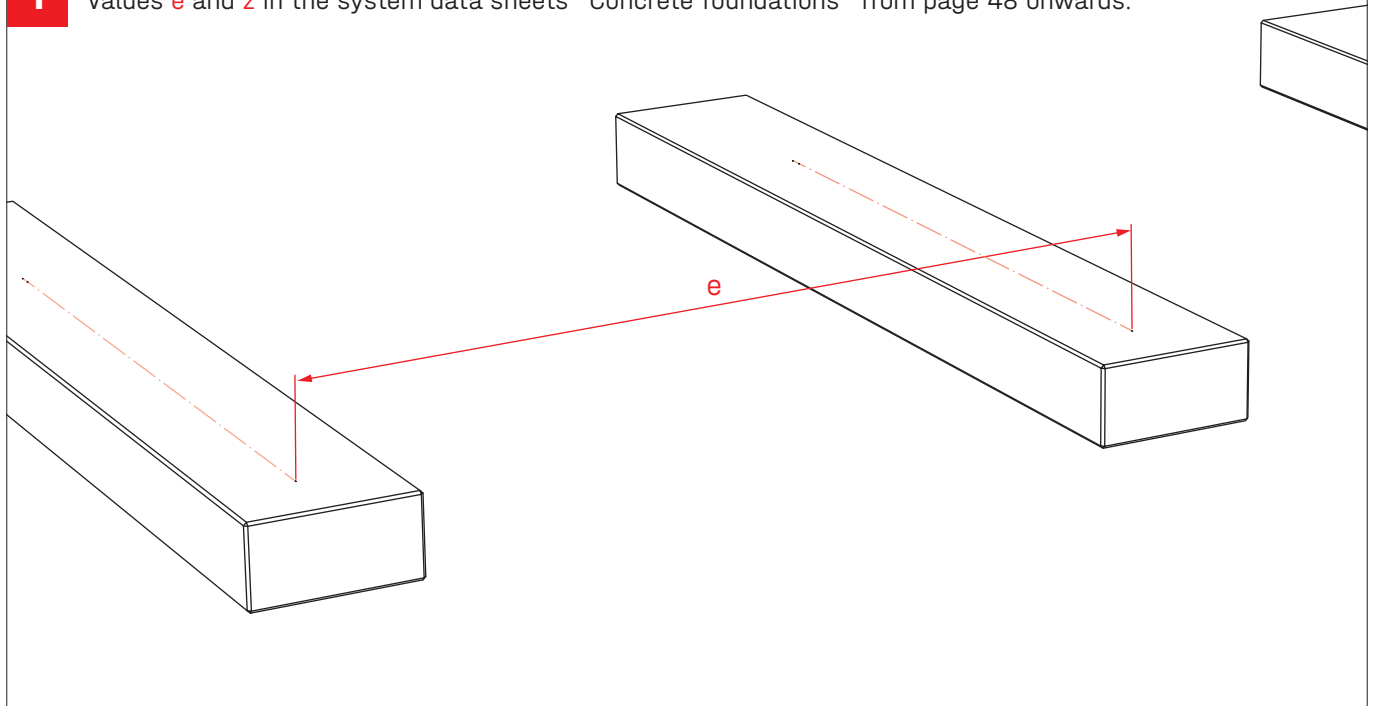

Pre-drilled anchor holes

2

Value z in the system data sheets "Concrete foundations" from page 48 onwards.

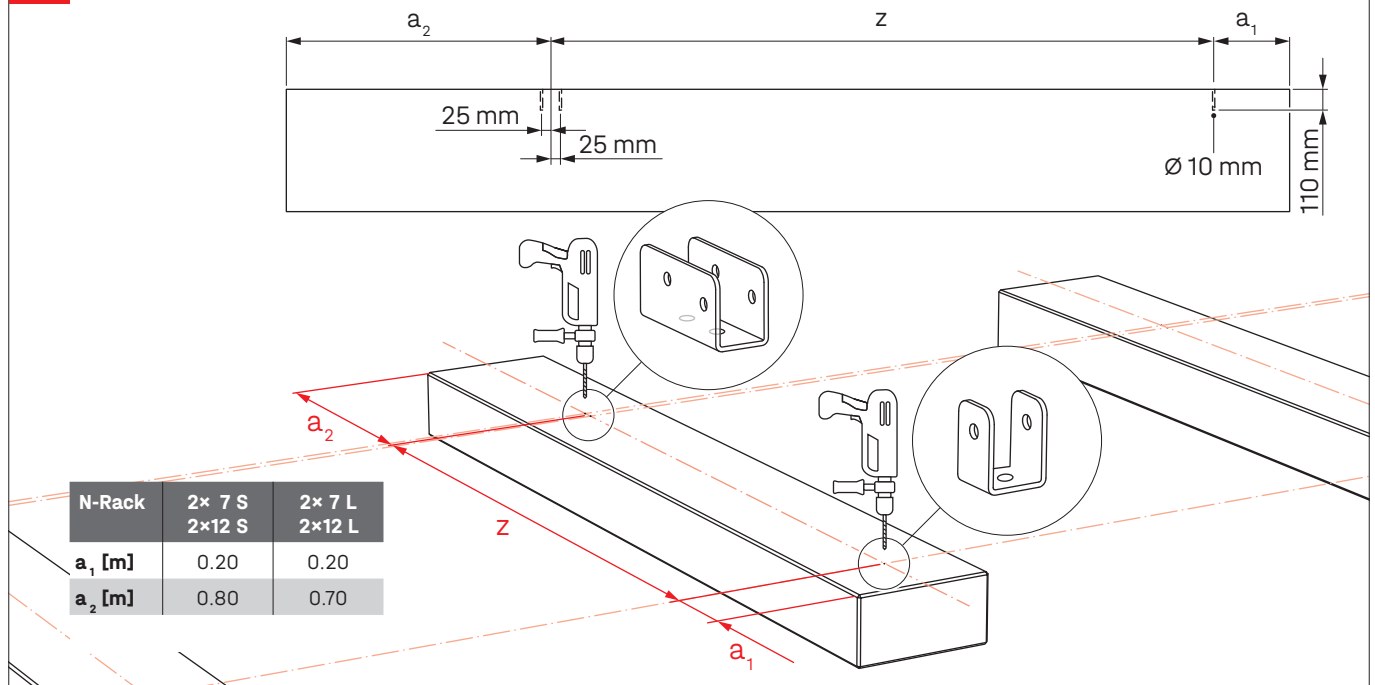

Fixing the anchors and connection

3

! 90 Nm

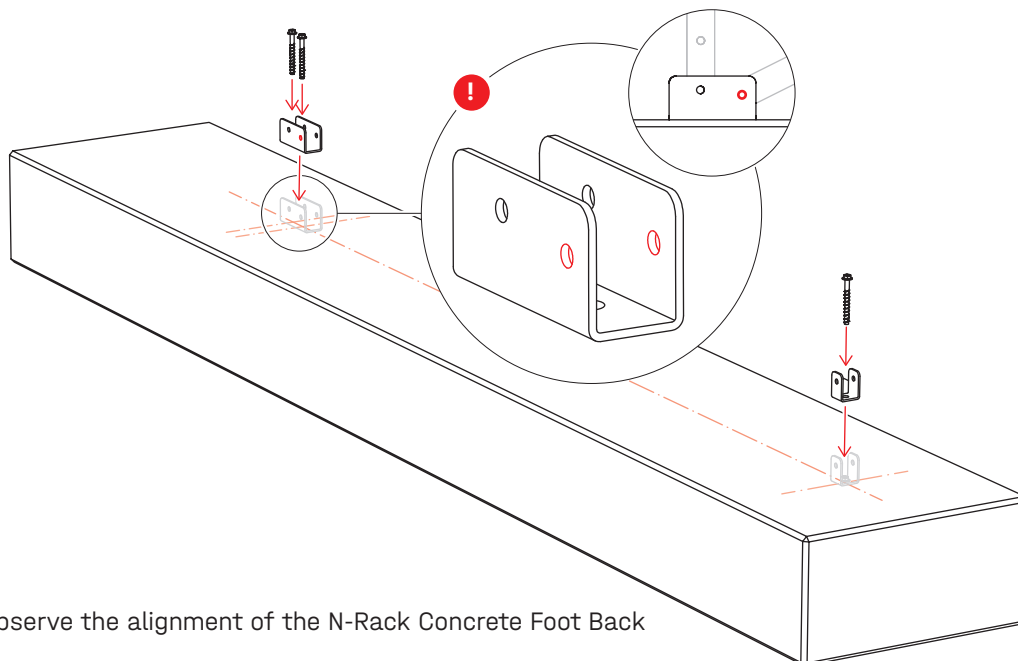

! Observe the alignment of the N-Rack Concrete Foot Back

Connecting supports

4  30 Nm

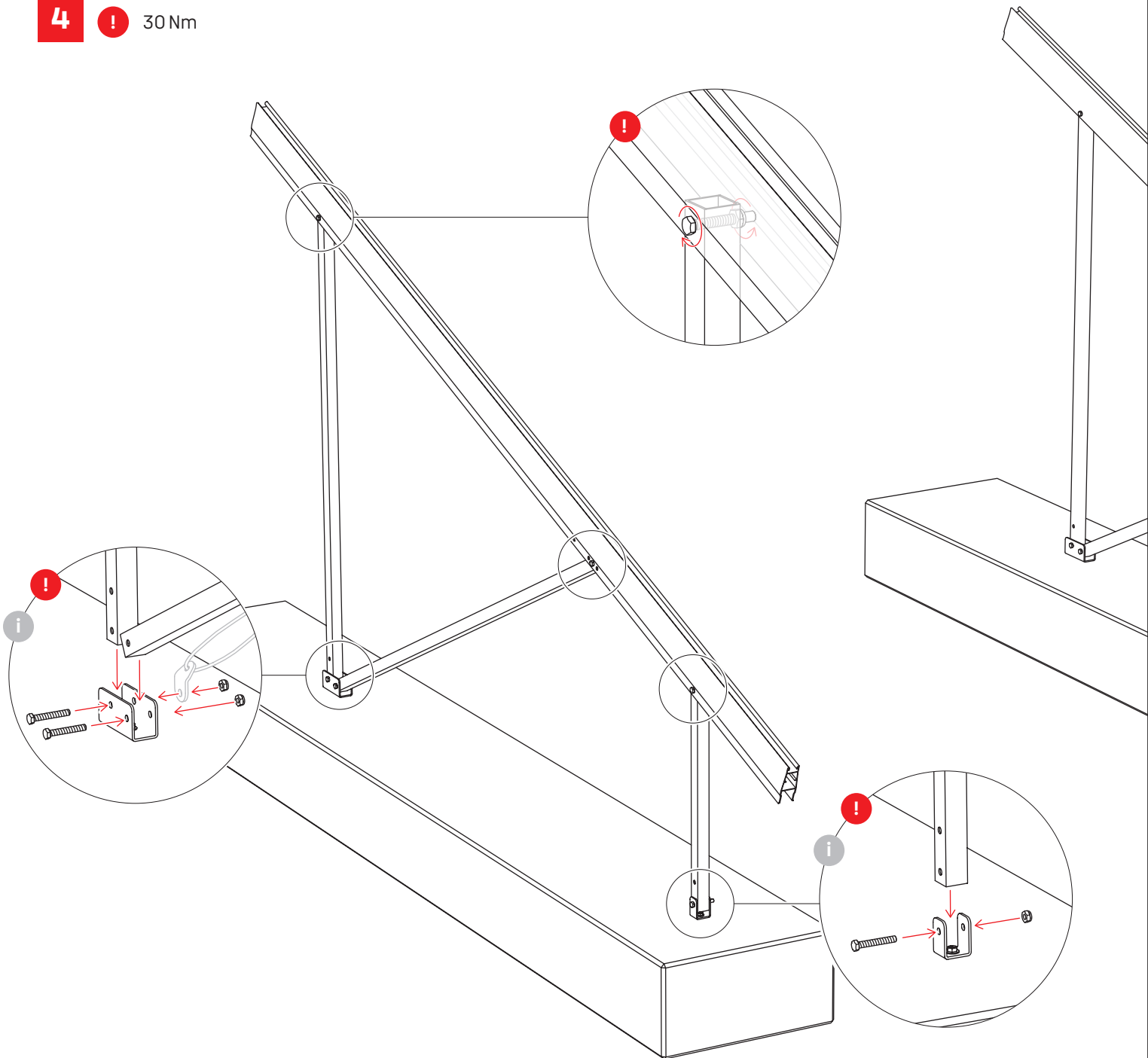

 Attaching the wind bracing to the outer concrete foundations. "Setting up wind bracing" on page 38.



Ground screw foundations

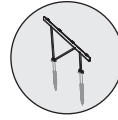

General guidelines



Subsoil assumption

The quantity and required size of the respective screw foundations always depends on the type of soil, size and weight as well as wind and snow loads on the planned structures. It is assumed that it will be soil class TL/TM in accordance with DIN 18196, with a semi-solid consistency (DIN 1422). The basis for the final foundation dimensions is the soil condition to be determined on site and the structural analysis of the load-bearing capacity, based on an applicable static calculation model.



Structural requirements

- Kit requirements
 - 1.2 - 1.25 m insertion depth of the Krinner M16 screw foundations to ≤ 1.75 kN snow and ≤ 0.67 kN wind

Additional tools

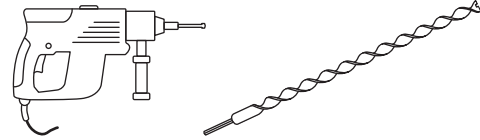

Drill hammer incl. drill 25 mm

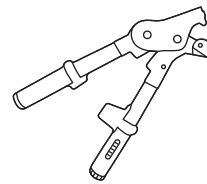

Gripple Collet Chuck 400 · 2004456



Equipment/machines for screwing in the ground screw foundations are available from a construction machinery rental facility. Alternatively, a garden and landscaping company can be commissioned.

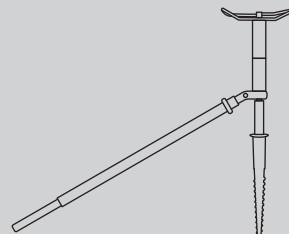

Ground screw driver, e.g.: Krinner KR E 20-SC

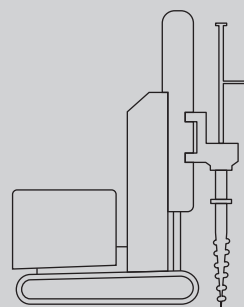

Self-driving caterpillars, e.g.: Krinner KR D 30-C0

Components

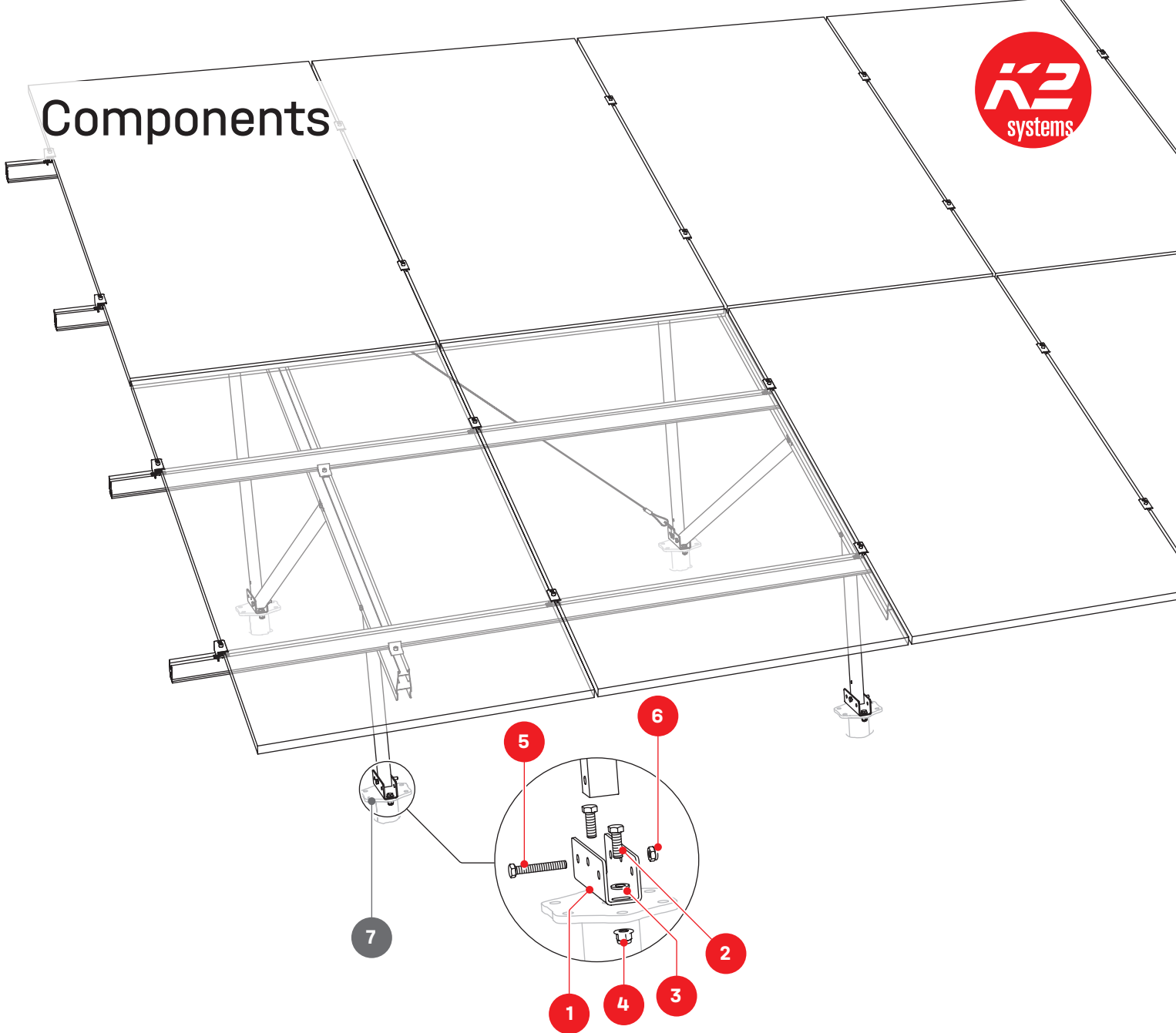

N-Rack Ground Kit Ground Screw

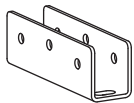

1 2004896
N-Rack GS Foot



2 2004902
Hexagon Head Screw
M12 x 35



3 2004910
Washer M12



4 2004903
Hexagon nut with
flange M12



5 2004408
Hexagon Head Screw
with Shank M10 x 70



6 1002849
Hexagon Locking
Nut M10

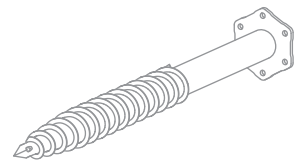

7 2005095
Screw Foundations 1.30 m
KSF M76 1300 M16
To be sourced separately..

Required - not included

Installation

Foundation work and spacing

1

Values e and z in the system data sheets "Ground screw foundations" from page 56 onwards.

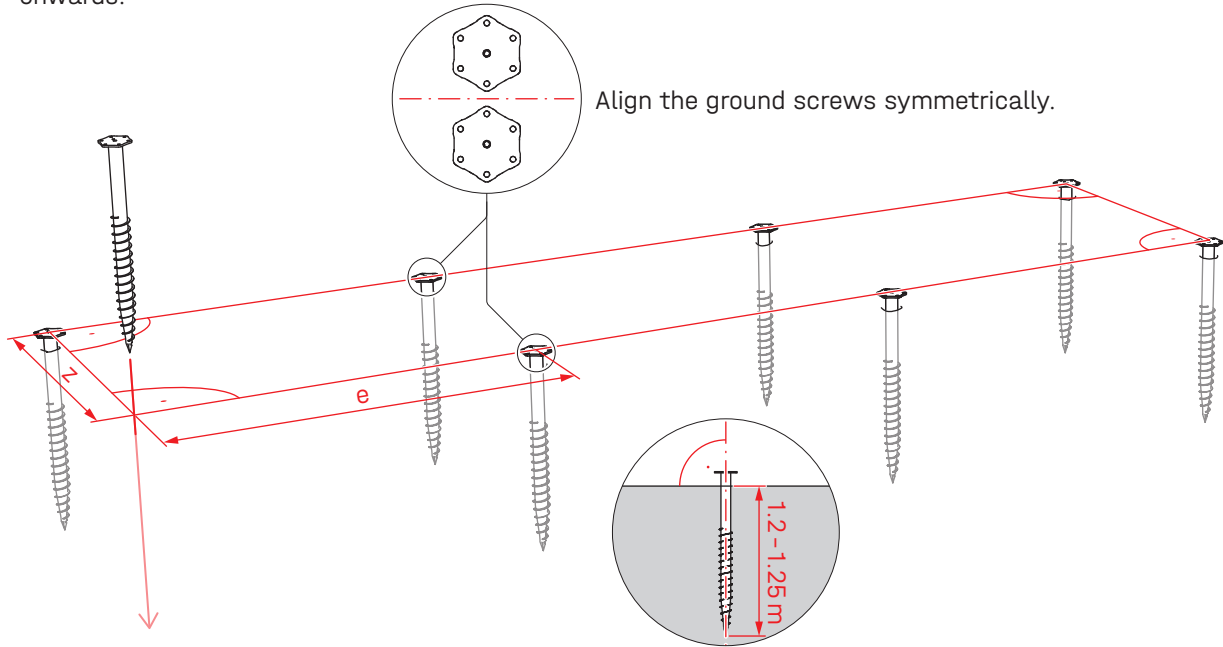

2a



54 Nm

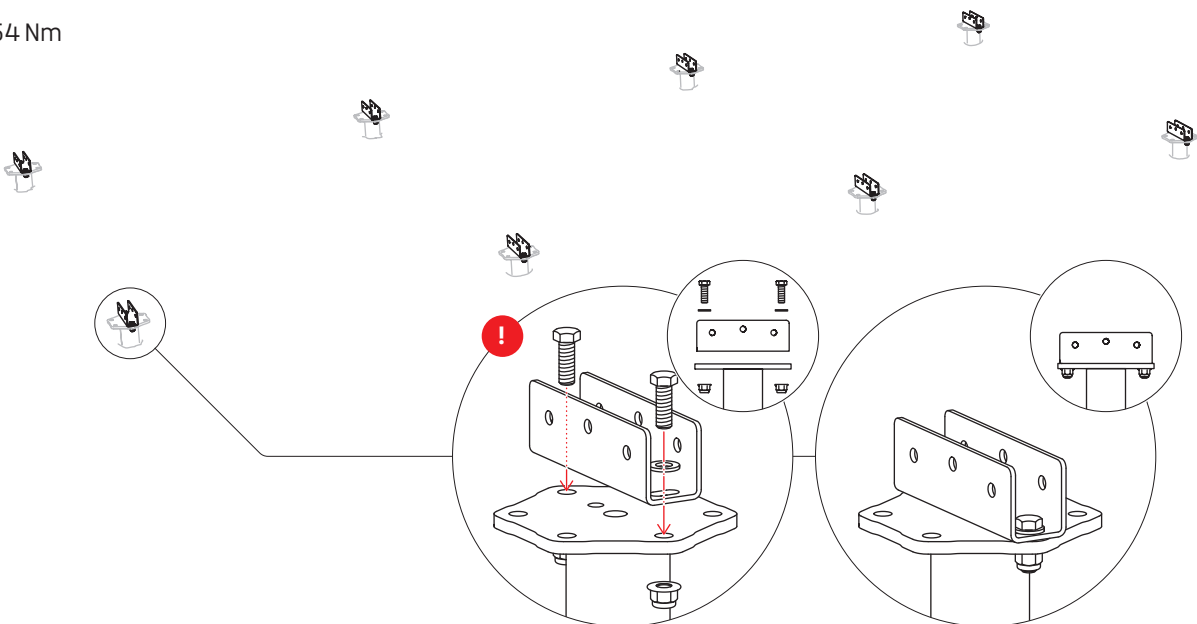

Connecting supports

2b  30Nm

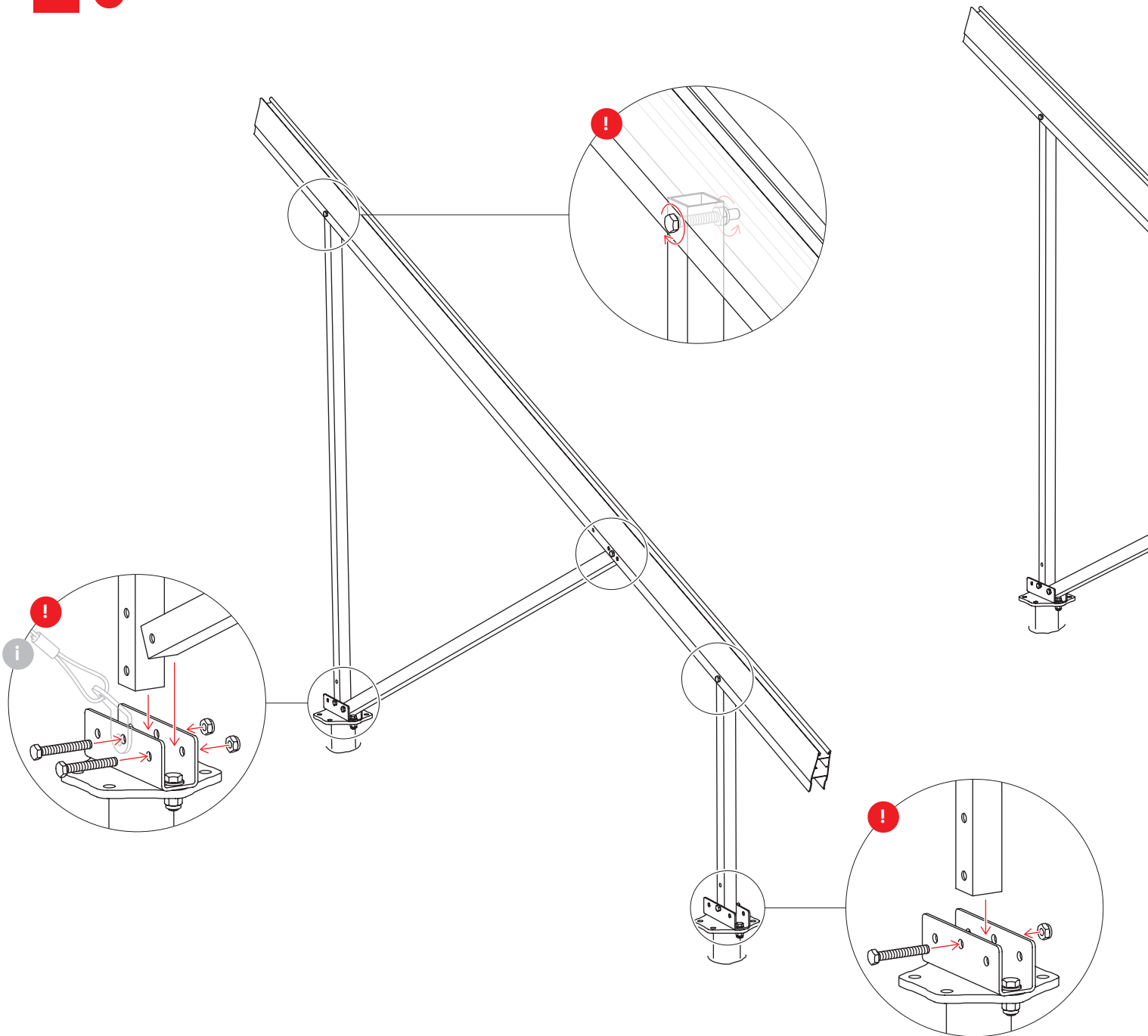

 Attaching the wind bracing: "Setting up wind bracing" on page 38.

Pile-driven foundations



General guidelines



Soil requirements

The quantity and required size of the respective piles always depends on the type of soil, size and weight as well as wind and snow loads on the planned structures. It is assumed that it will be soil class TL/TM in accordance with DIN 18196, with a semi-solid consistency (DIN 1422). The basis for the final foundation dimensions is the soil condition to be determined on site and the structural analysis of the load-bearing capacity, based on an applicable static calculation model.

Structural requirements

Kit requirements

- 1.8 - 1.9 m insertion depth of the K2 cap profile
- ≤ 1.75 kN now and ≤ 0.67 kN wind

Additional tools

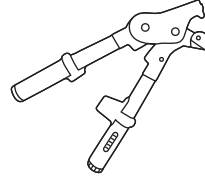

Gripple Collet Chuck 400 · 2004456



Equipment/machines for inserting the ramming foundations are available from a construction machinery rental facility. Alternatively, a garden and landscaping company can be commissioned.

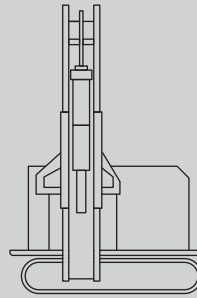

Piling machine

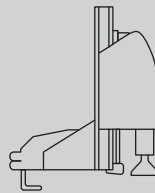

Pile driver for attaching to a mini excavator, etc.

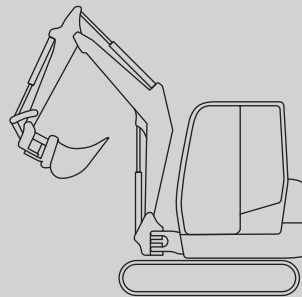

Excavator

Components

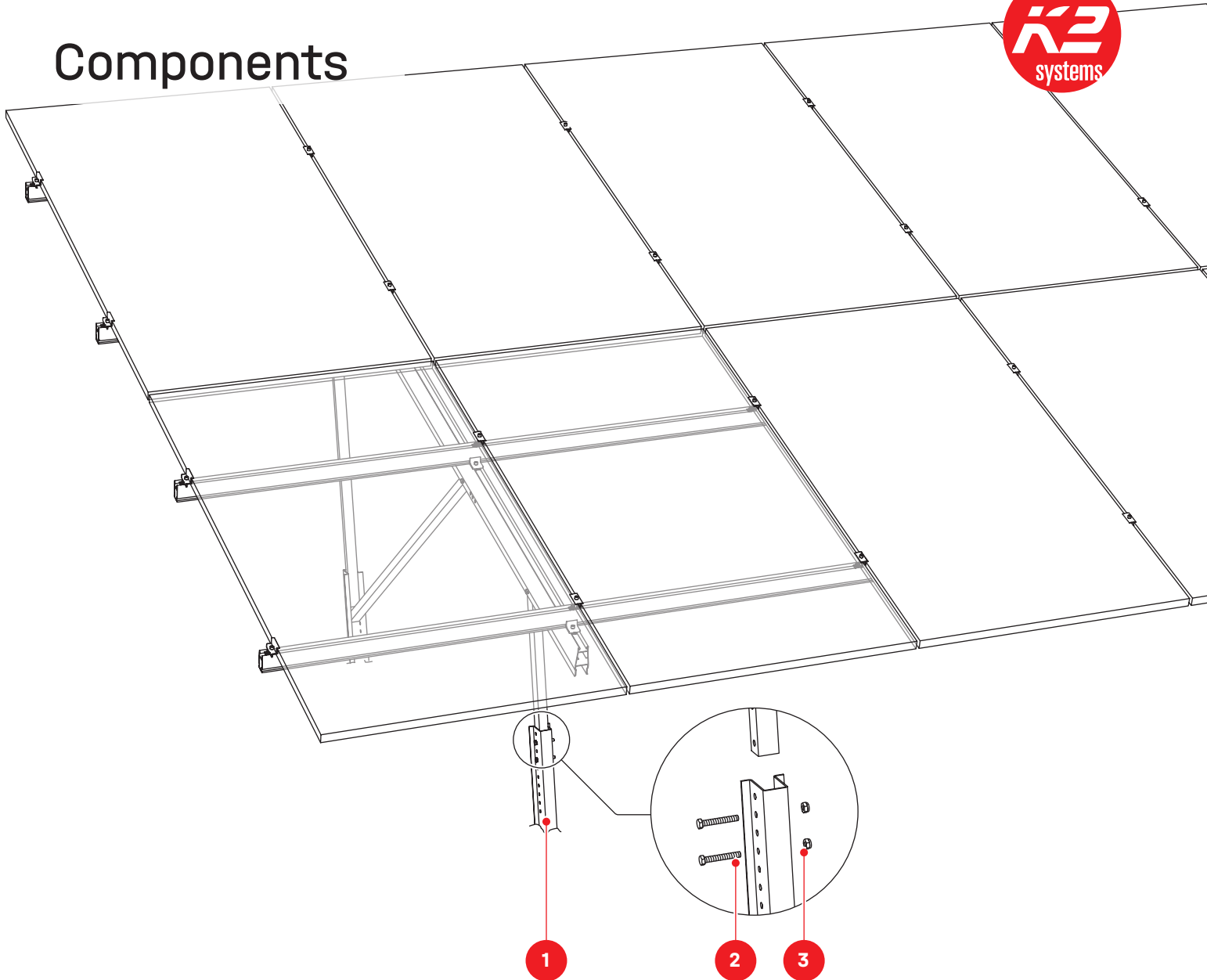

N-Rack Ground Kit Pile

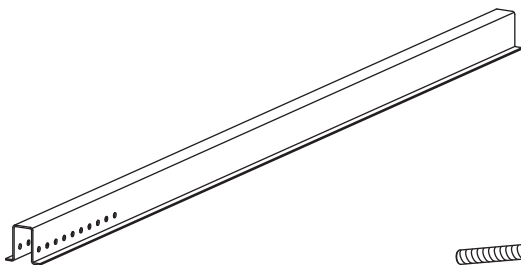

1 2005112
Cap Profile
N-Rack 2,3 m

2 2004408
Hexagon Head Screw
with Shank M10 × 70

3 1002849
Hexagon Locking Nut
M10

Installation

Foundation work

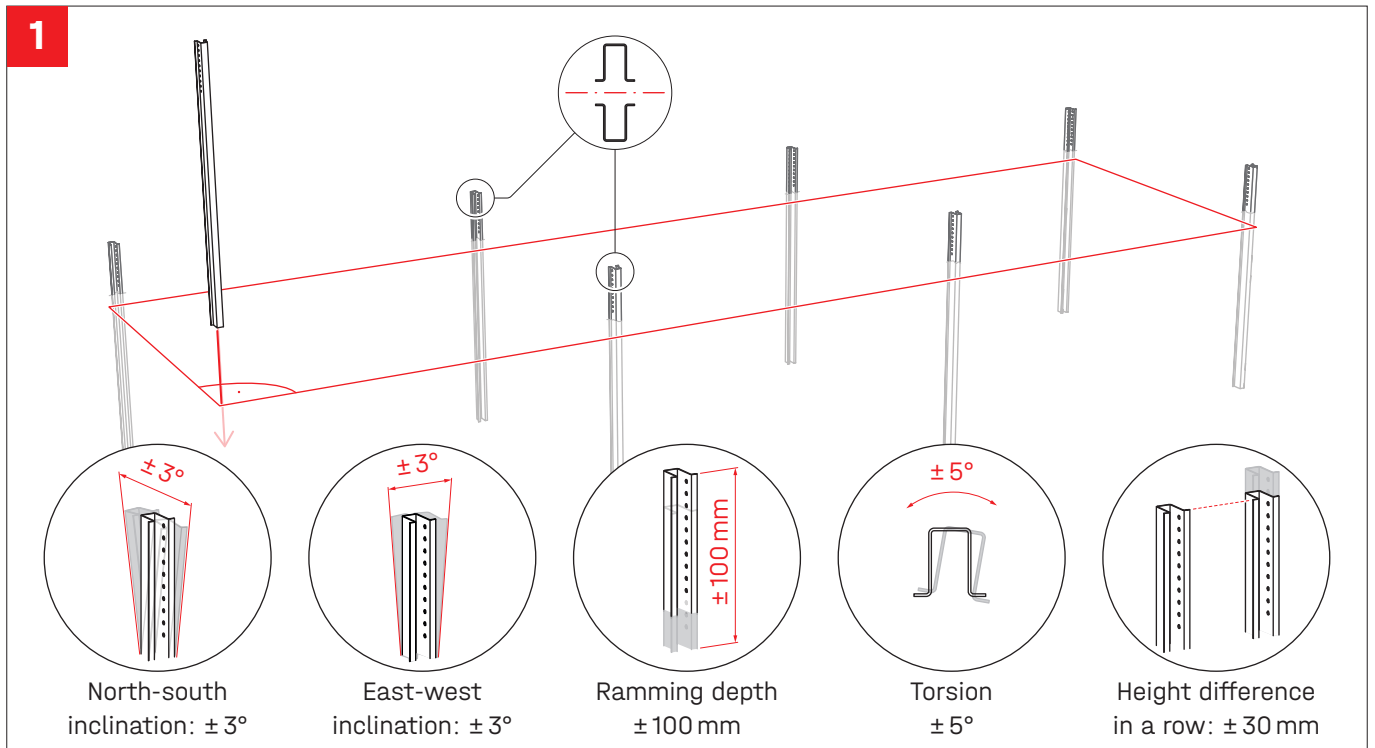

Spacing

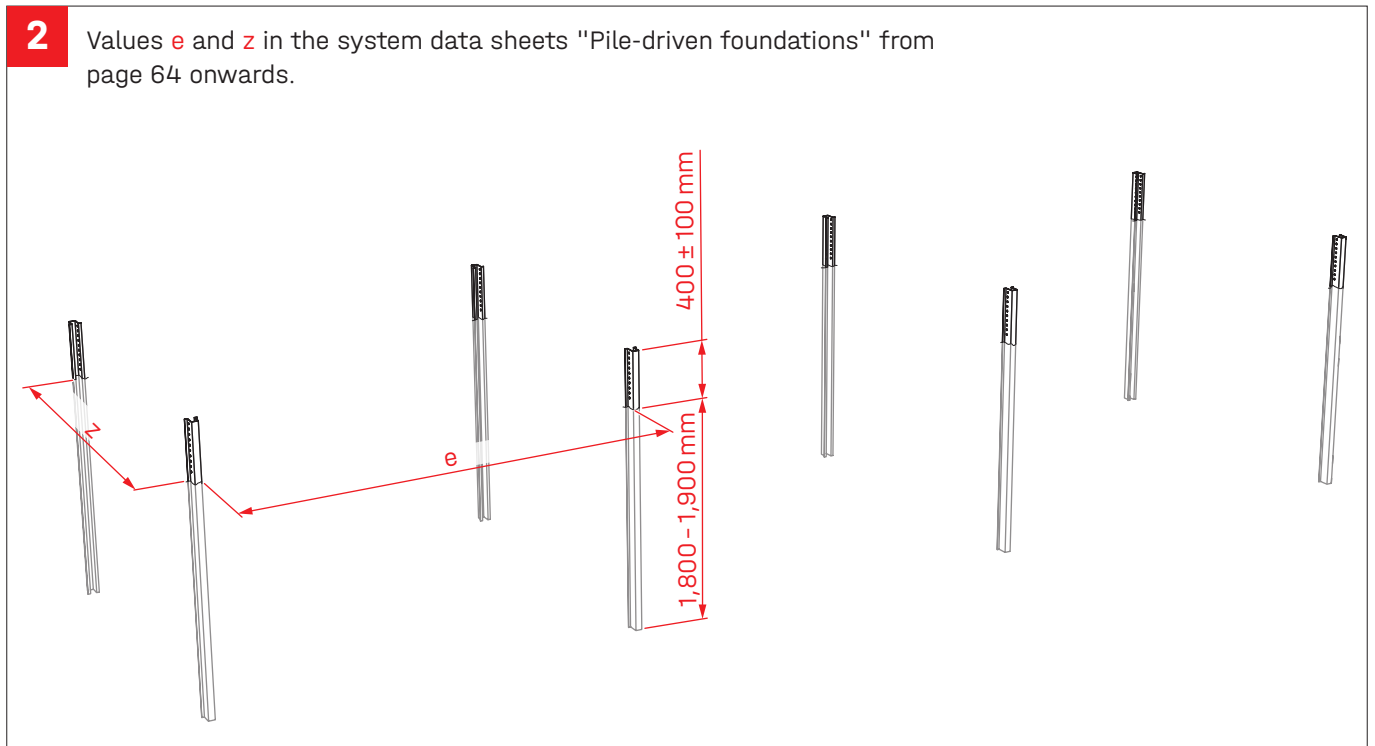

Connecting supports

3 ! 30 Nm

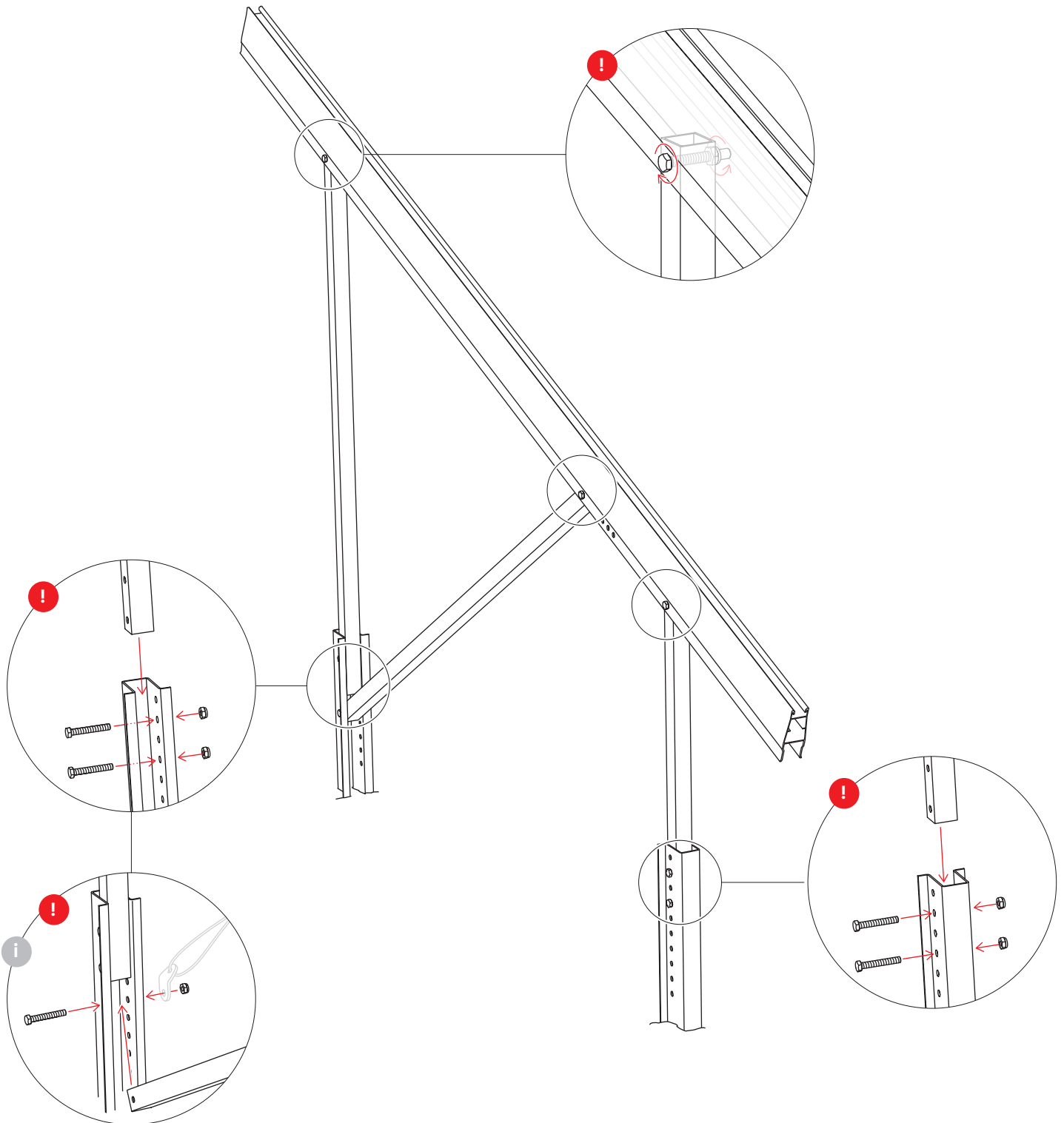

i Attaching the wind bracing: "Setting up wind bracing" on page 38.

Installing mounting rails and modules

Components from the N-Rack Top Kit

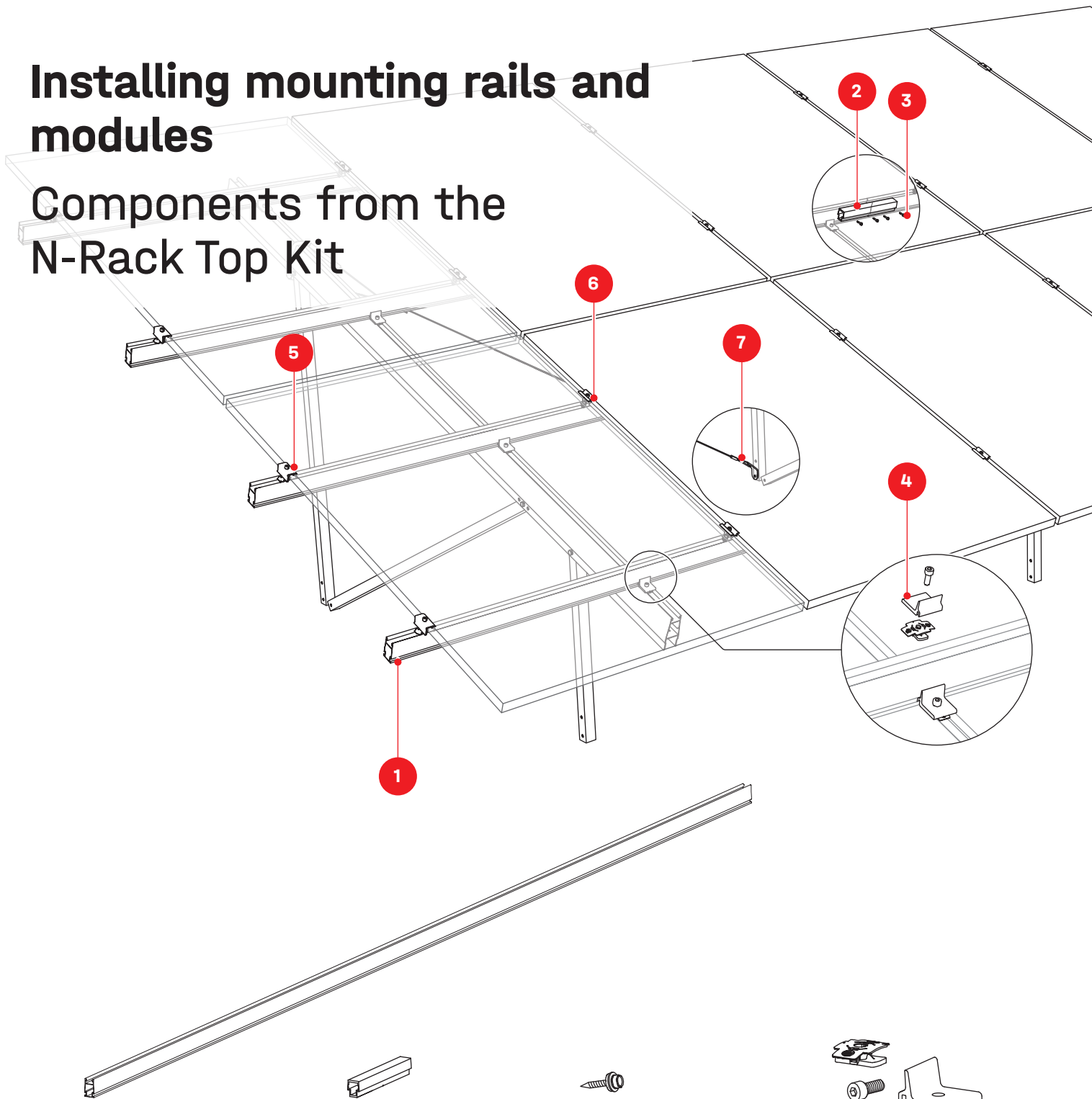

1 System-specific article number, see page 8
CrossRail 73

2 2004409
CrossRail 73 Connector

3 1001051
Drilling Screw 5.5 × 25

4 2003145
Climber 36/50 Set

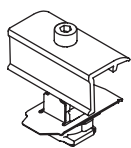

5 2004543
Module Clamp K2 Clamp EC 25 - 40

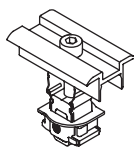

6 2004146
Middle Module Clamp K2 Clamp MC 25 - 40

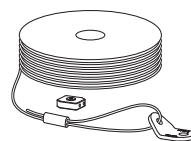

7 2004410
Wind Bracing Set

Installation

1a M = Module length. The clamp position and the modules must be arranged symmetrically with the length of the upper flange. Observe the manufacturer's installation manual for the permissible clamping range.

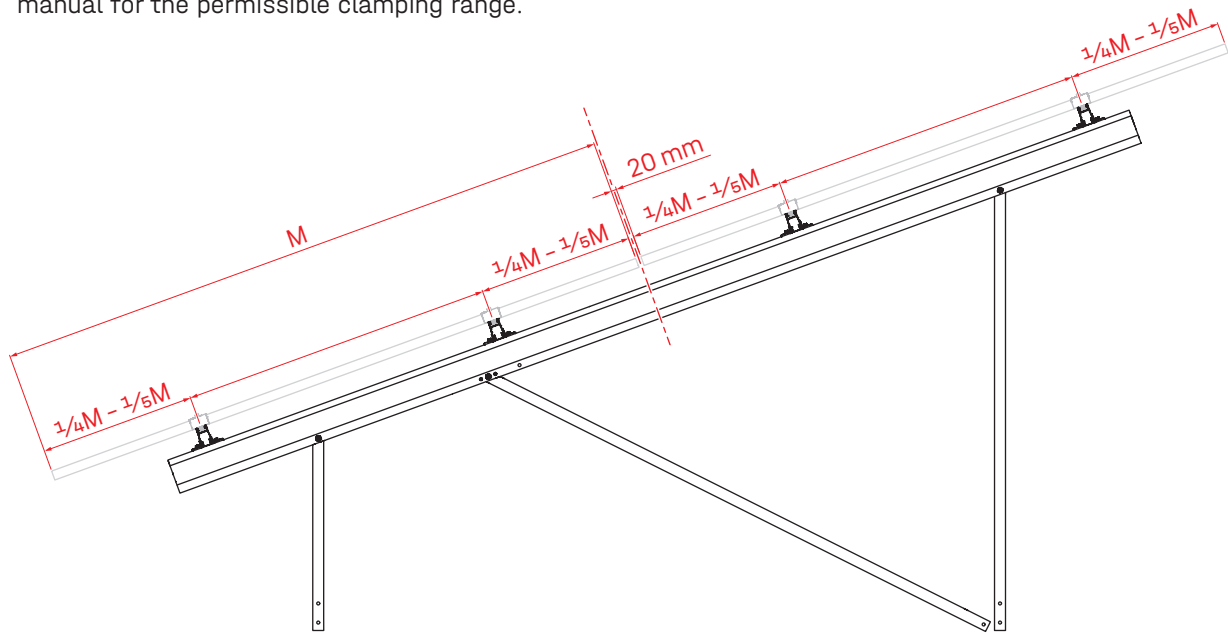

1b

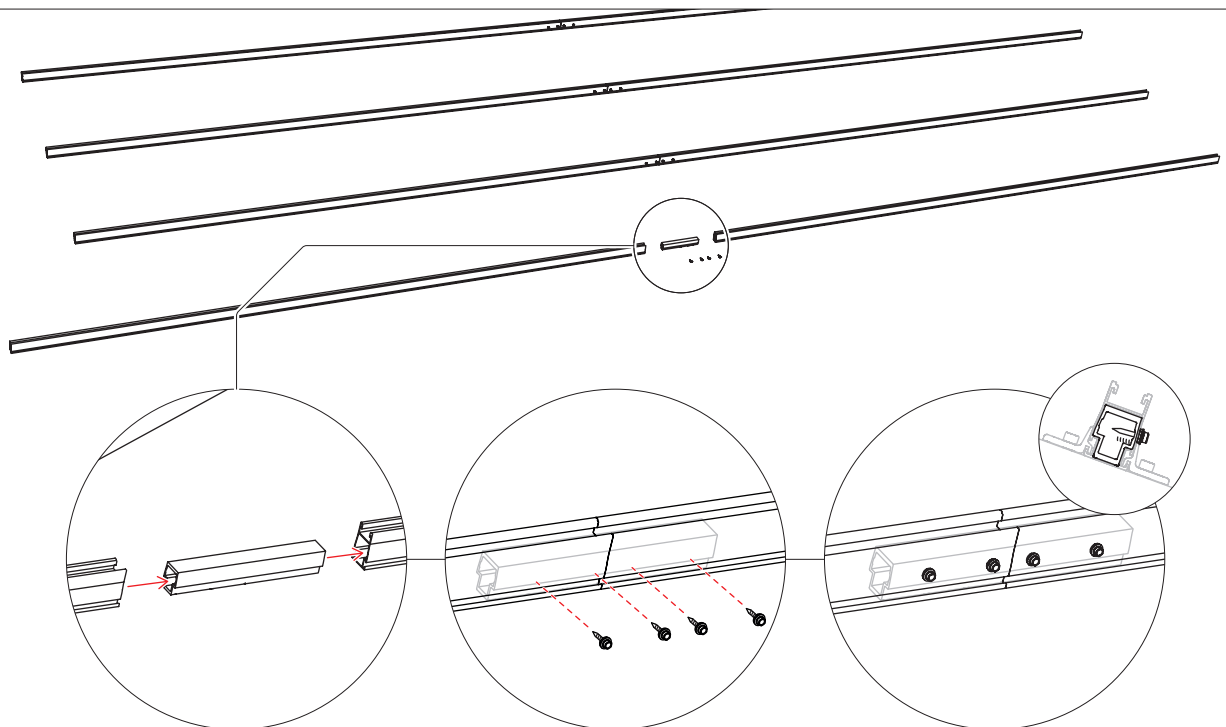

Connecting the CrossRail mounting rail

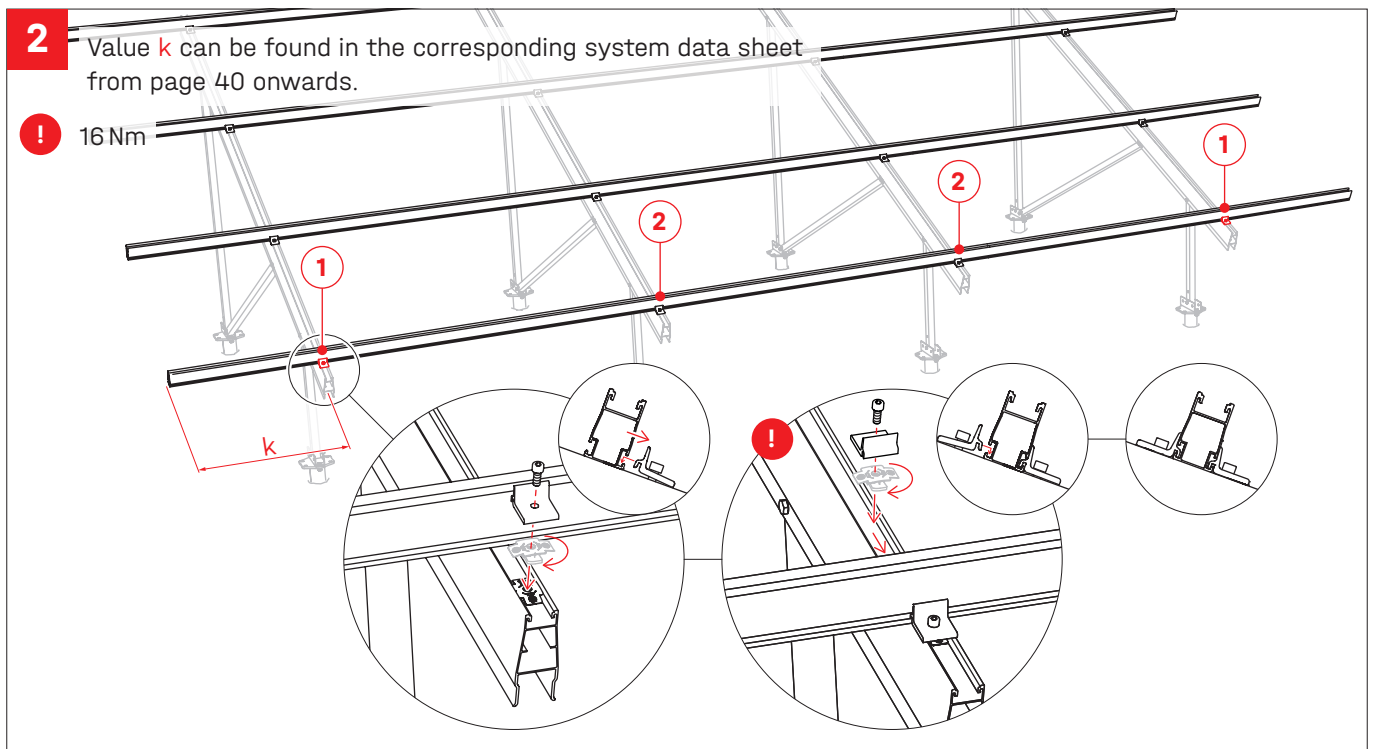

Module installation

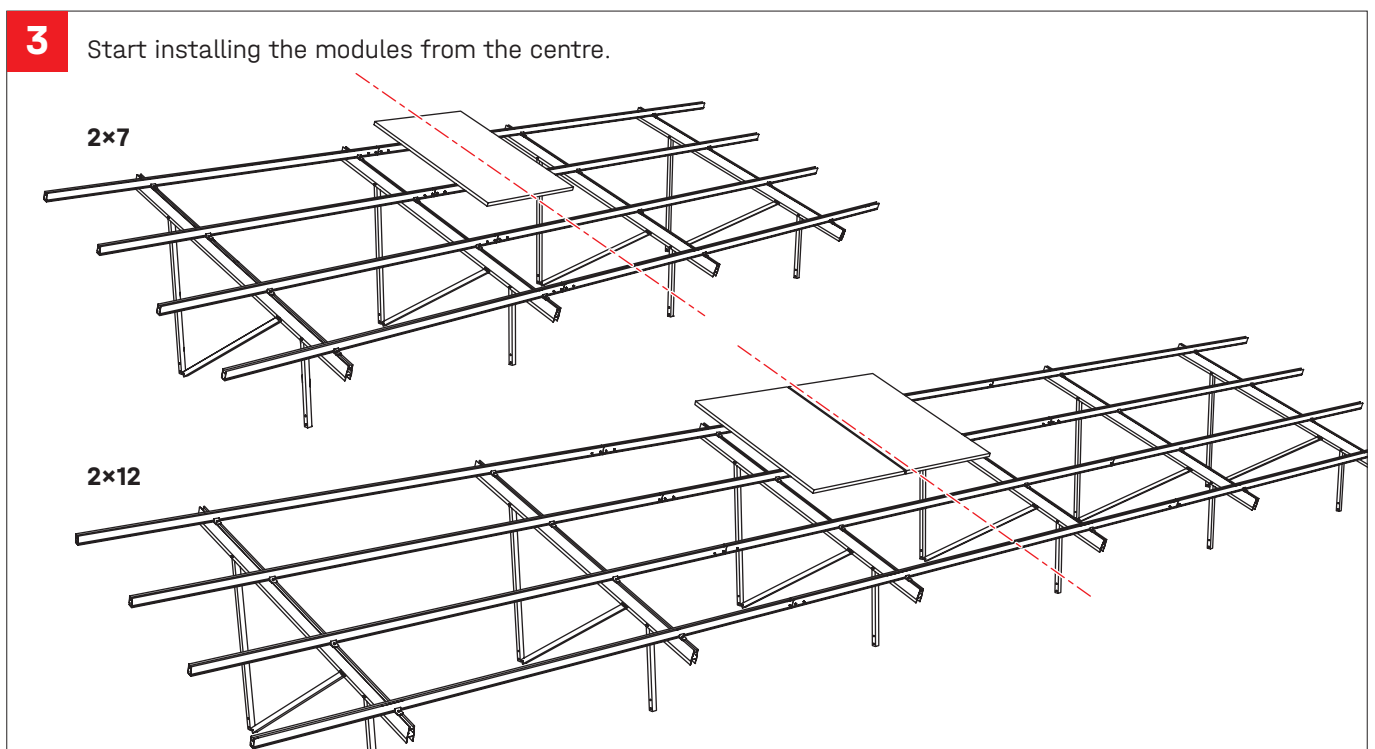

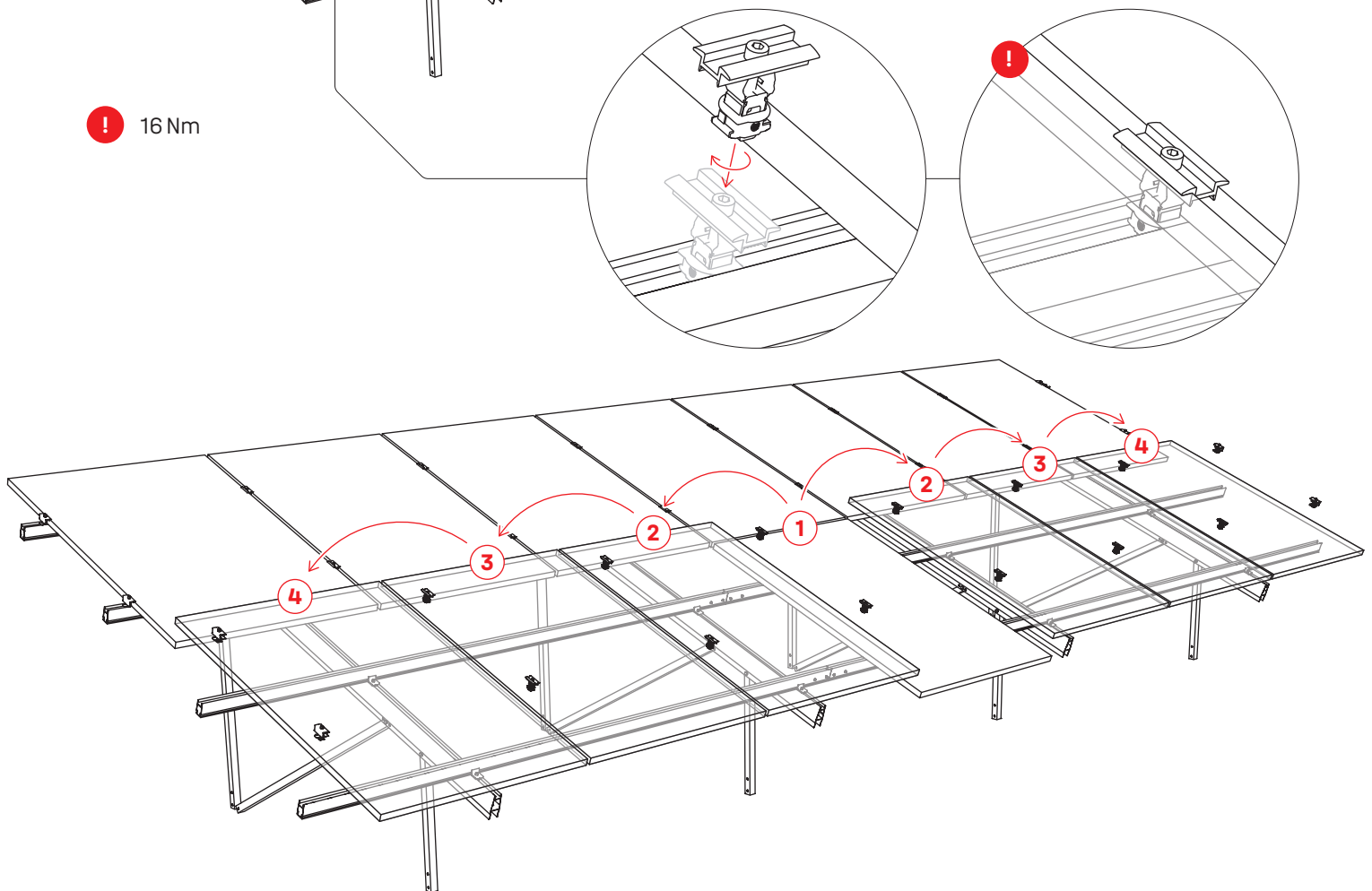
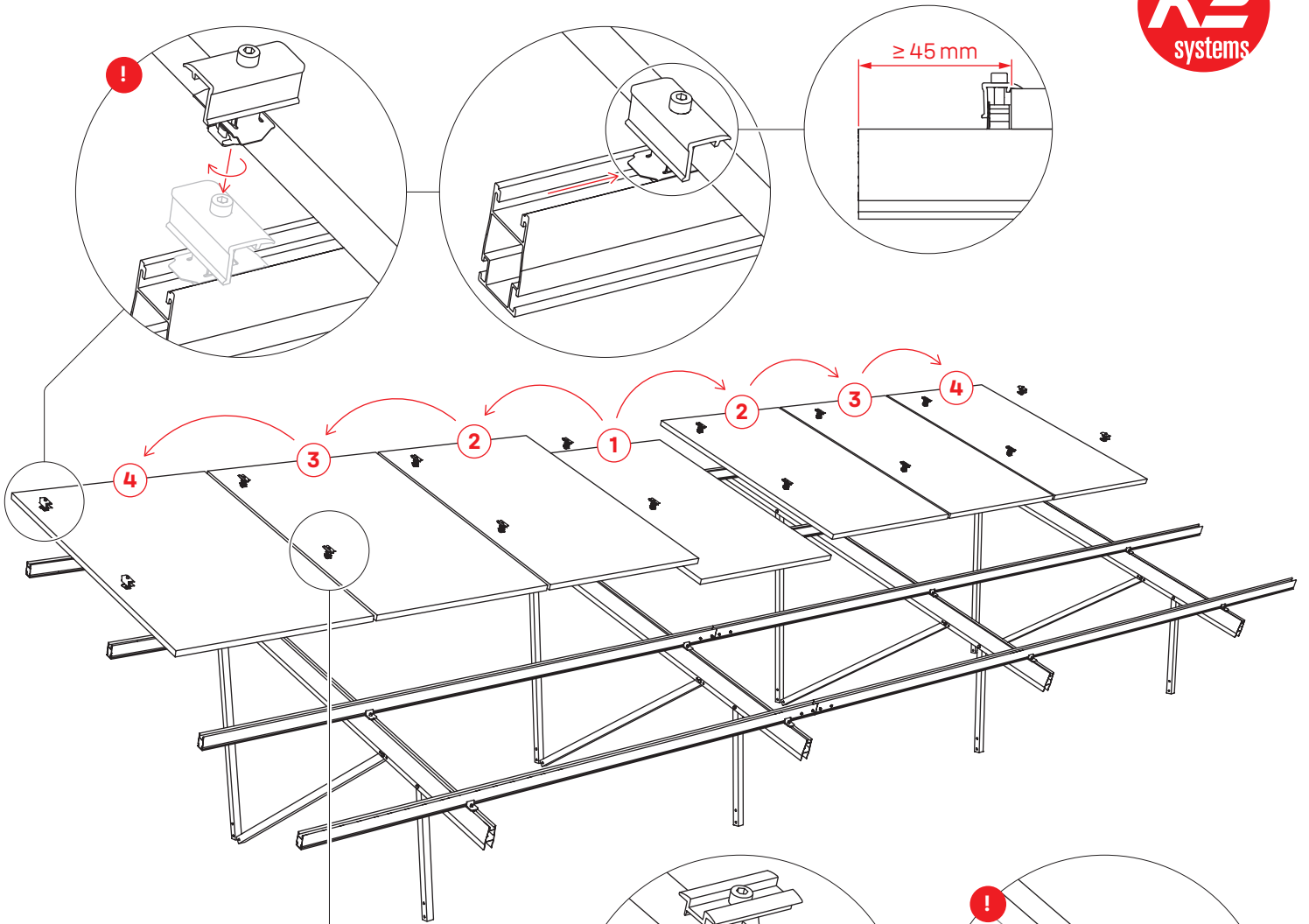

Setting up wind bracing

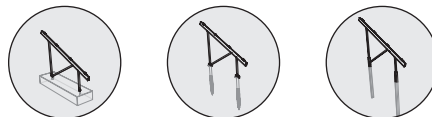

The wind bracing is mounted only at the outermost bays of the N-Rack table. Only two of the four wind braces included in the Top Kit are required.
No wind bracing is required for the N-Rack Kit with gabions.

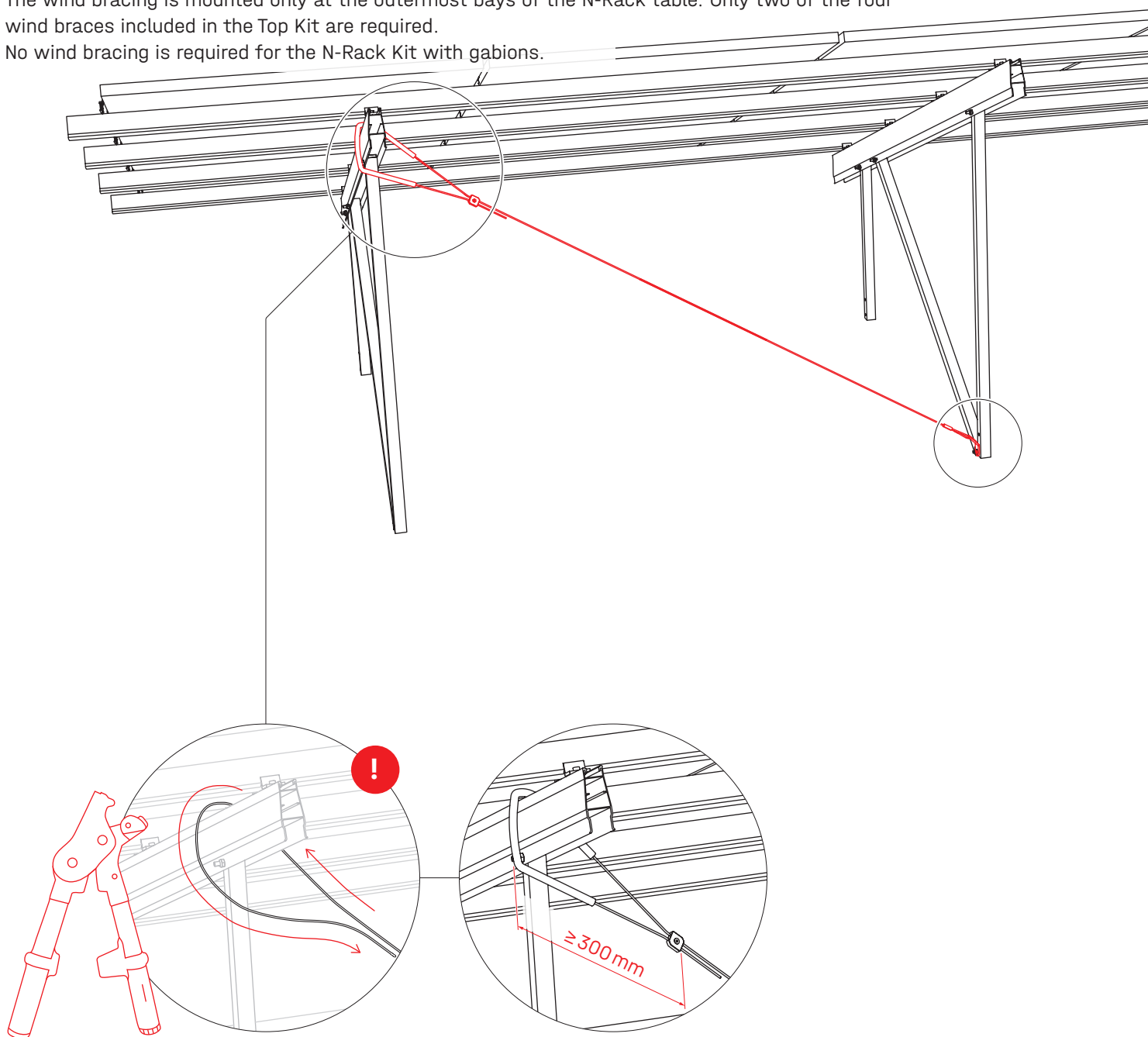

 Observe the tool manufacturer's application instructions

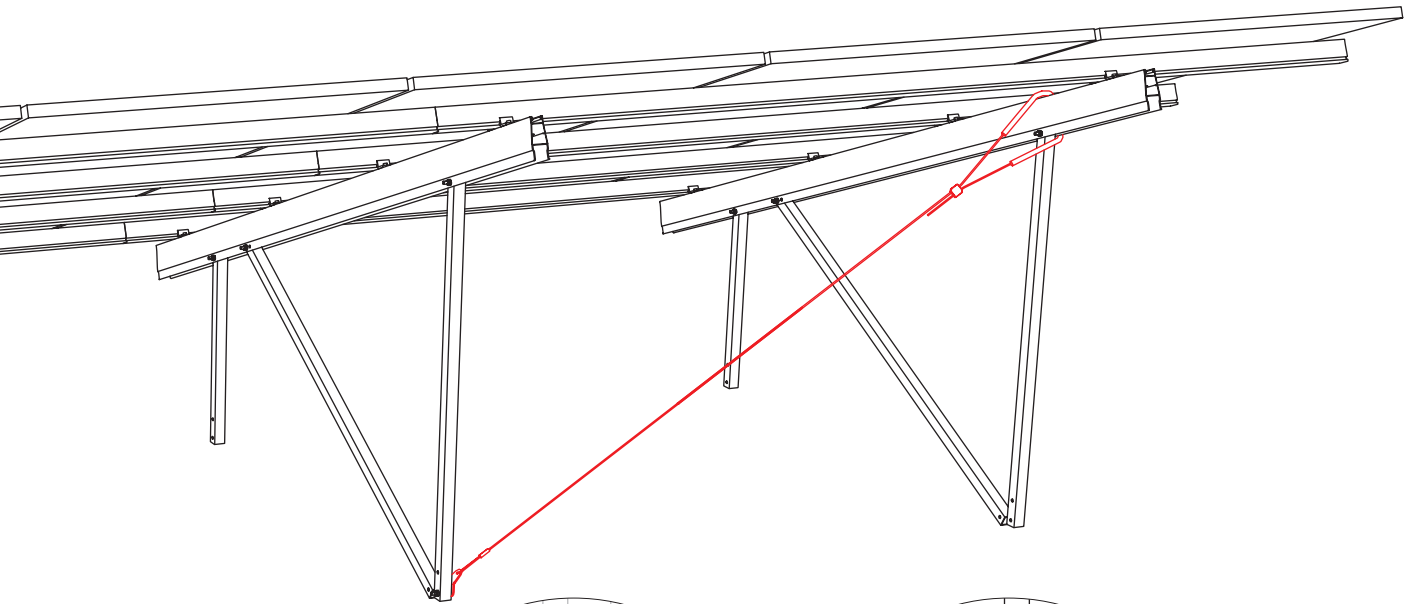

Concrete foundations

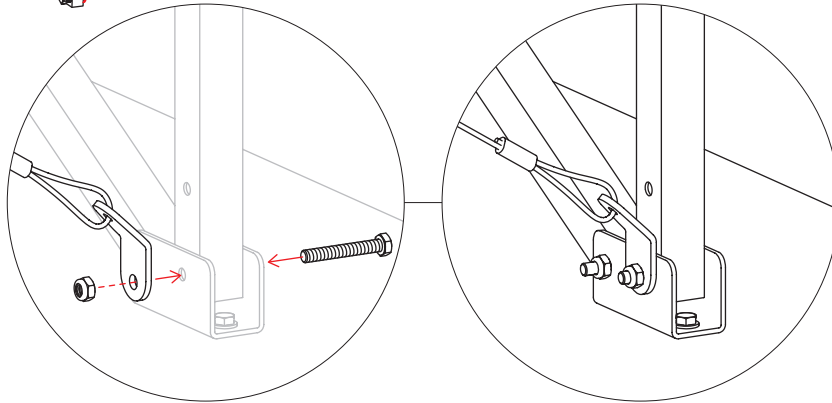

Ground screw foundations

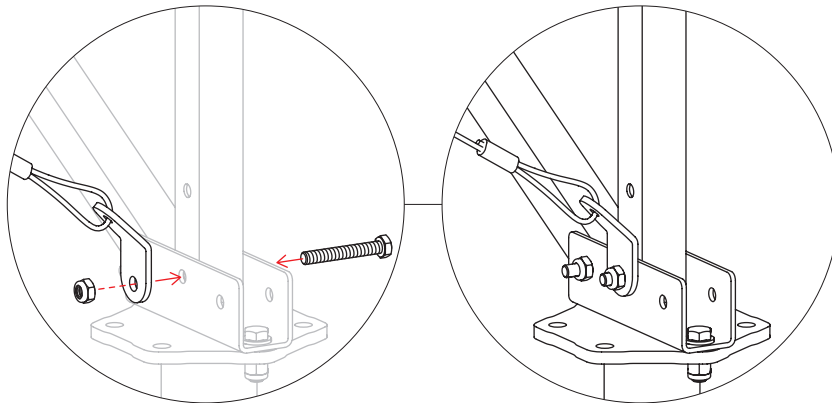

Pile-driven foundations

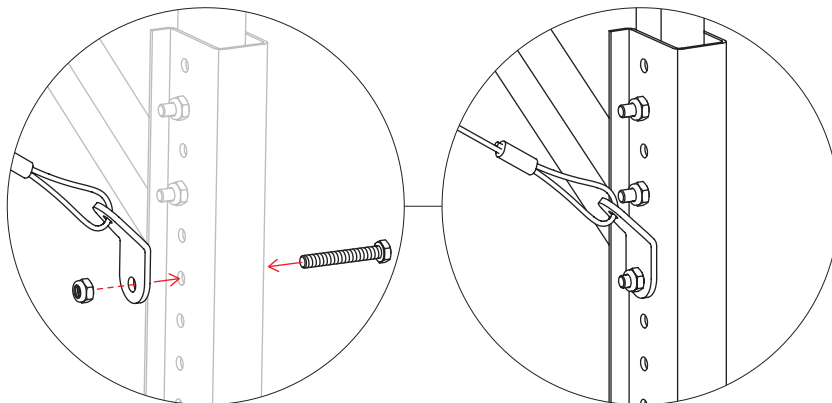



Connecting Strength

Thank you for choosing a K2 mounting system.

Mounting systems from K2 Systems are quick and easy to install. We hope these instructions have helped. Please contact us with any questions or suggestions for improvement. Our contact data:

- k2-systems.com/en/contact
- **Service Hotline: +49 7159 42059-0**

Our General Terms of Business apply. Please refer: k2-systems.com

K2 Systems GmbH

Haldenstraße 1 · 71272 Renningen · Germany
+49 (0) 7159 - 42059 - 0 · info@k2-systems.com · k2-systems.com

N-Rack Kits Assembly EN V1 | 0526 · Subject to change
Product illustrations are exemplary and may differ from the original.