

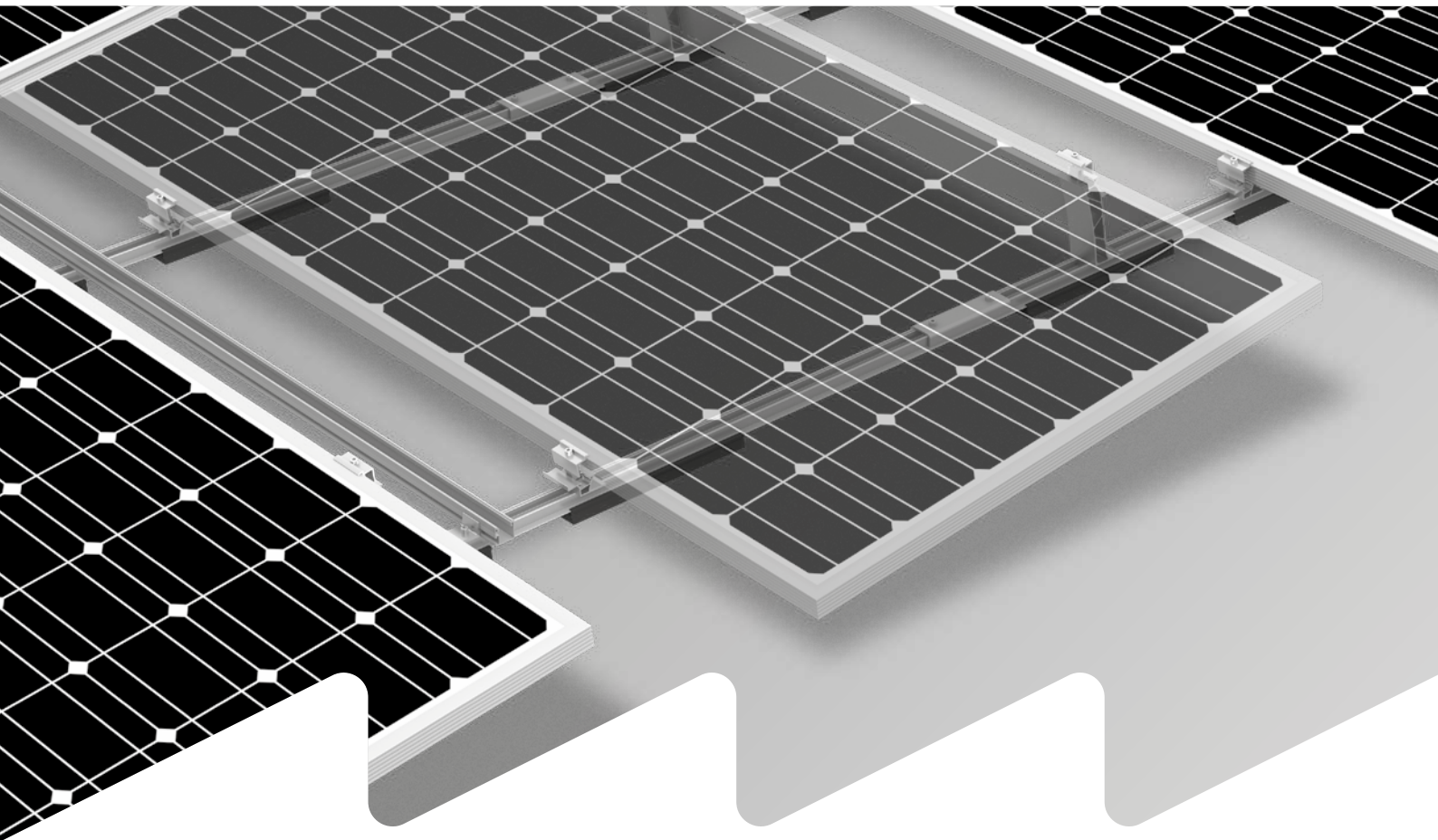

**Connecting Strength**



 Assembly instructions

# **S-Dome 6 System**

## **Classic LS**

# Content

• Tools overview	3
• General safety information	4
• The following guidelines apply	5
· Planning with K2 Base	5
· Roof requirements	5
· Static requirements	5
· Important mounting instructions	5
• Components	6
· Base components	6
· Ballast	8
· Fixed connection to the roof	9
• Assembly	10
· Installation of module field and thermal separations	10
· Module assembly	15
· Assembly Windbreaker	17
· Ballasting options and specifications	18
• Optional assembly steps	20
· Fixed connection with Dome FixPro using Solmont mounting base	20
· Cable-Manager	21
· Module frame earthing with TerraGrif K2MI	21
• Notes	22

## Quality tested - several certifications

K2 Systems stands for secure connections, highest quality and precision. Our customers and business partners have known that for a long time. Independent institutes have tested, confirmed and certified our capabilities and components.

Please find our quality and product certificates under:

[k2-systems.com/en/technical-information](https://k2-systems.com/en/technical-information)

# Tools overview

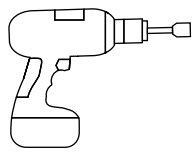

6 mm



8 mm

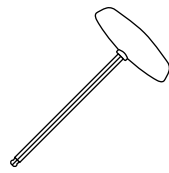

6 mm

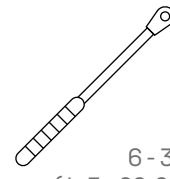

6 - 30 Nm  
(4.5 - 22.2 lb-ft)



6 mm

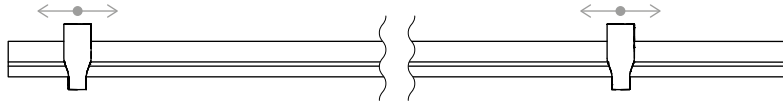

**Dome Speed Spacer Large** · 2004129  
Distance template for module lengths

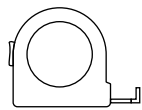

≥ 3.0 m



≥ 6.0 m

## Digital Toolbox



**Do you already know our digital services?** Use our K2 Roof Check App now and record the first important data directly at the customer or project site.

Simply transfer the data to our online planning software K2 Base.

Here you can plan your project easily, safely and quickly. You receive a detailed project report with assembly plan and static report.

The K2+ interface enables seamless project data transfer to the planning tools of other manufacturers. With the K2 DocuApp, project documentation is done quickly and easily - without annoying paperwork.

**Get started and register now:**

[base.k2-systems.com](https://base.k2-systems.com) →

[docuapp.k2-systems.com](https://docuapp.k2-systems.com) →

# General safety information

Please note that our general mounting instructions must be followed at all times and can be viewed online at [k2-systems.com](https://k2-systems.com)

- The equipment may only be installed and operated by qualified and adequately trained installers.
- Prior to installation, ensure that the product complies with on-site static loading requirements. For roof-mounted systems, the roof load-bearing capacity must always be checked.
- National and local building regulations and environmental requirements must be adhered to.
- Compliance with health and safety regulations, accident prevention guidelines and applicable standards is required.
  - Protective equipment such as safety helmet, boots and gloves must be worn.
  - Roofing works must be in accordance with roofing regulations utilising fall protection safeguards when eaves height exceeds 3 m.
  - At least two people must be present for the duration of the installation work in order to provide rapid assistance in the event of an emergency.
- K2 mounting systems are continuously developed and improved and the installation process may thereby change at any time. Prior to installation consult our website at [k2-systems.com/en/technical-information](https://k2-systems.com/en/technical-information) for up-to-date instructions. We can send you the latest version on request.
- The assembly instructions of the module manufacturer must be adhered to.
- Equipotential bonding/grounding/earthing between individual parts is to be performed according to country specific standards, as well as national laws and regulations.
- At least one copy of the assembly instructions should be available on site throughout the duration of the installation.
- Failure to adhere to our general safety and assembly instructions and not using all system components, K2 is not liable for any resulting defects or damages. We do not accept liability for any damage resulting in the use of competitor's parts. Warranty is excluded in such cases.
- German law shall apply excluding the UN Convention on CISG. Place of venue is Stuttgart. Our General Terms of Business apply.
- If all safety instructions are adhered to and the system is correctly installed, there is a product warranty entitlement of 12 years! We strongly recommend reviewing our terms of guarantee, which can be viewed at [k2-systems.com/en/warranty-terms-and-conditions](https://k2-systems.com/en/warranty-terms-and-conditions) We will also send this information on request.
- Dismantling of the system is performed in reverse order to the assembly.
- K2 stainless steel components are available in different corrosion resistance classes. Each structure or component must be carefully checked for possible corrosion exposure.

# The following guidelines apply



The S-Dome 6 Classic LS system can be installed as standard under the following conditions. Even if the system is capable of meeting higher demands through the integration of safety standards, please get in touch with your contact at K2 Systems if the specified values are exceeded..



## Planning with K2 Base

We recommend our free online software K2 Base for the planning. In five steps, you can plan the right assembly system and get a construction recommendation, parts list and the structural analysis report. Simply register and start planning:

[base.k2-systems.com](https://base.k2-systems.com)



## Roof requirements

- This system can be installed on all common flat roofs with a pressure-resistant substrate and a roof pitch of  $\leq 3^\circ$  without a fixed connection.
- Fixed connection  $> 3^\circ$  to  $\leq 10^\circ$ 
  - Up to  $\leq 5^\circ$  combinations with ballast possible
  - $> 5^\circ$  to  $\leq 10^\circ$  only without ballast
- The roof surface must be clean and dry. Roof irregularities must be corrected or removed where appropriate.
- The coefficient of friction of the roof must be determined on-site. See video

[k2-systems.com/en/friction-coefficient](https://k2-systems.com/en/friction-coefficient)



## Static requirements

- It is essential to check that the roof structure has sufficient residual load capacity and that the pressure capacity of the roof insulation (where present) is not exceeded.
- Suitable for framed modules with a frame height 30 - 50 mm
- Permissible module dimensions (length  $\times$  width):
  - **10°:** 1562 - 2390  $\times$  950 - 1170 mm
  - **15°:** 1562 - 2390  $\times$  950 - 1305mm



## Important mounting instructions

### Mounting system

- The exact mounting angle deviates slightly from  $10^\circ$  depending on the module width. This angle decreases with higher module widths.
- A minimum distance to the roof edge of 600 mm must be maintained. For building heights below 5 m, the minimum distance can be reduced.

- The compatibility of the roof covering and the Mat S support pad must be checked.
- An array must consist of at least two elevations must for this mounting system to be properly utilized.
- Ensure a thermal separation (distance between module blocks) in the direction of the base rail and module rows must be maintained:
  - Base rail: 12.3 m
  - Module row : 16.0 m
- In the event of exceptional circumstances (such as storms, heavy rain, earthquakes, etc.), the system should be checked by a specialist. Should an inspection find damage or plastic deformation (such as in the module clamp area) the components must be replaced.

### Modules and clamping

- Tightening torque of 14 Nm for all module clamps.
- Adhere to module manufacturer recommendations for clamping area and module installation (see module manufacturer instructions). Check whether manufacturer approval is available for clamping on the short module side. See [k2-systems.com/en/approved-modules-dome-6](https://k2-systems.com/en/approved-modules-dome-6)

### General information

- External influences that act on this system are only reflected in the design of the ballast to a limited degree. For instance, unevenness, thermal elongation, moss, water accumulation and ageing of the sheeting cannot be considered, although these factors might also precipitate system displacement under certain circumstances. We therefore recommend regular maintenance of the system or to check whether additional mechanical fastening is necessary.
- It is important to ensure that the rain water flow is not hindered.
- On-site general standards and regulations for lightning protection must be observed and consultation with a specialist to create a lightning protection concept is recommended (use lightning protection clamp if necessary).

# Components

## Base components

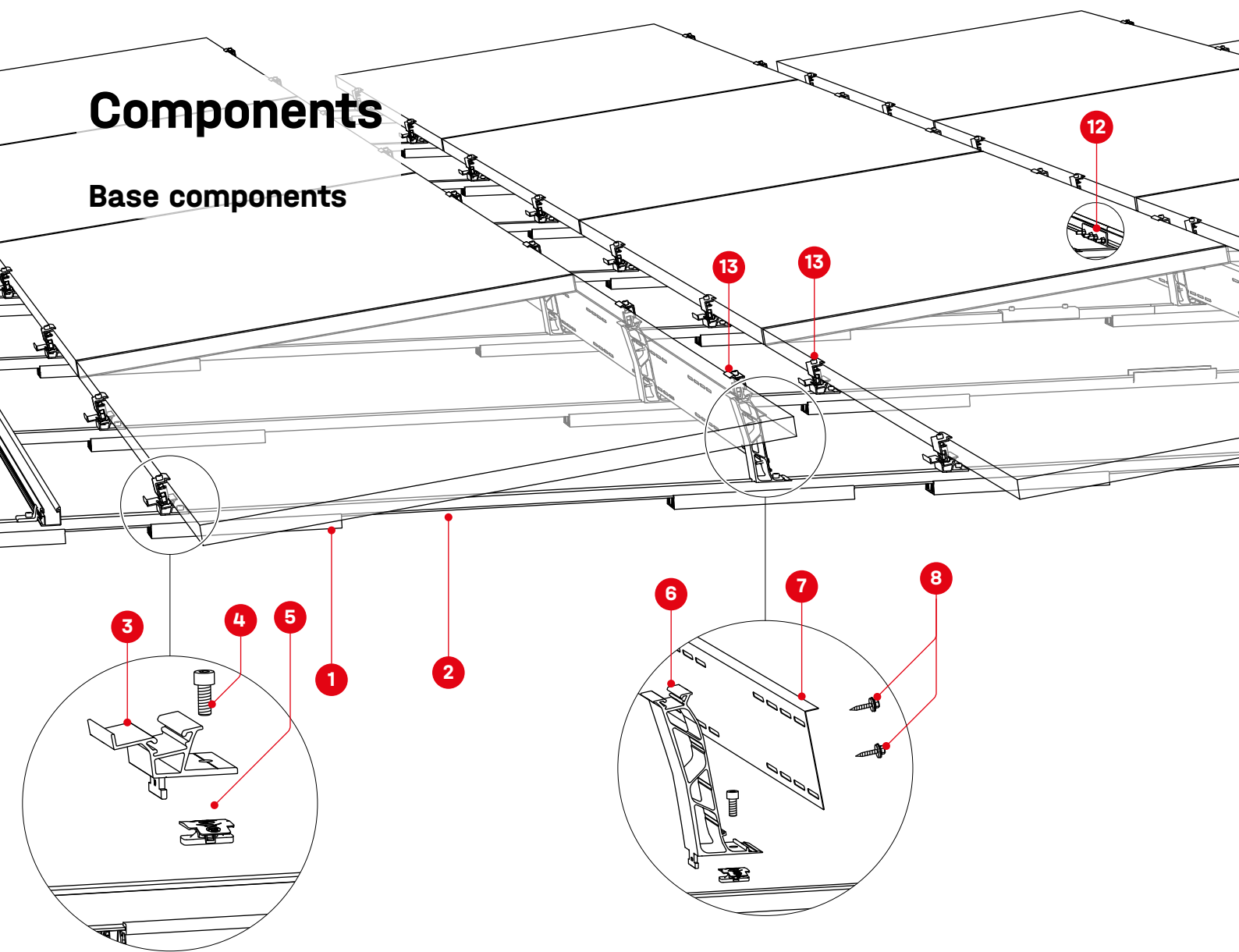

**1** 2003126  
**Mat S**

**2** Article number  
system-specific  
**BasicRail 22**

**3** 2003243 / 2004175  
**Dome 6.10 / 6.15 SD**

**4** 1001643 + 2001729  
**5** **MK2 Slot nut with clip +  
Allen bolt M8×20**

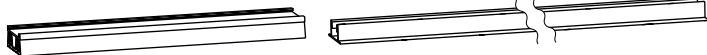

**6** 2004125 / 2004174  
**Dome 6.10 / 6.15 Peak**

**7** 2004167 / 2004183  
**S-Dome 6.10 / 6.15  
Windbreaker LS**

**8** Article number  
system-specific  
**Thread-forming  
tapping screw with  
sealing, 6 × 25**

**9** 1006039  
**FlatConnector Set**

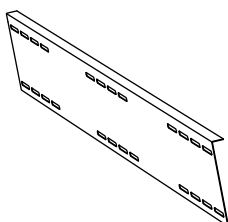
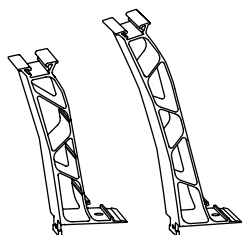

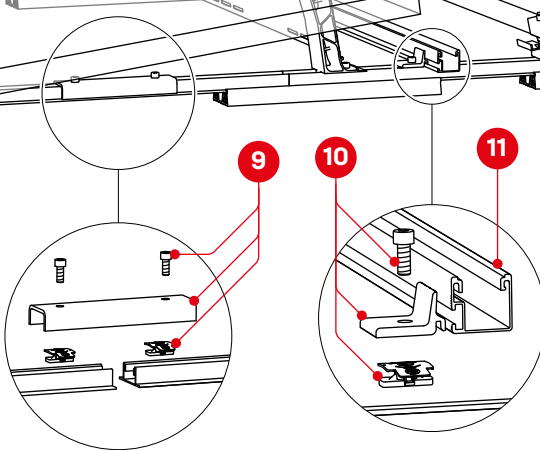
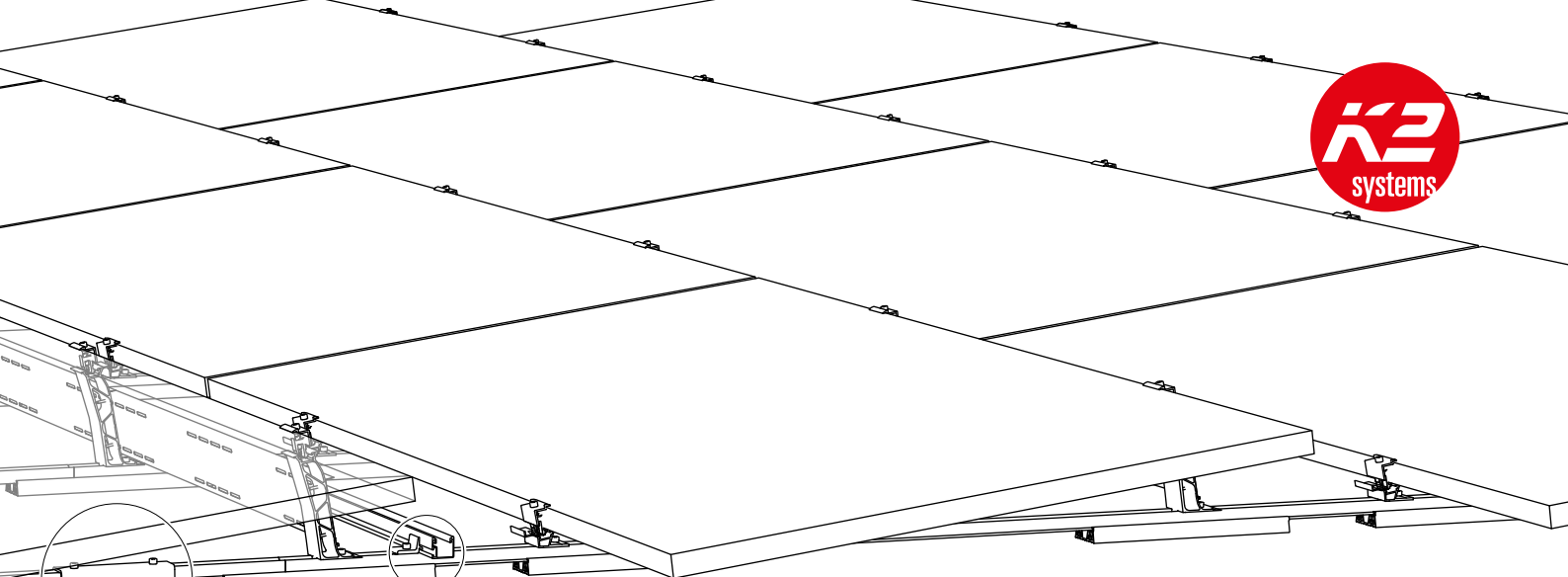

## Dome 6 distance template

2004129

Dome Speed Spacer Large

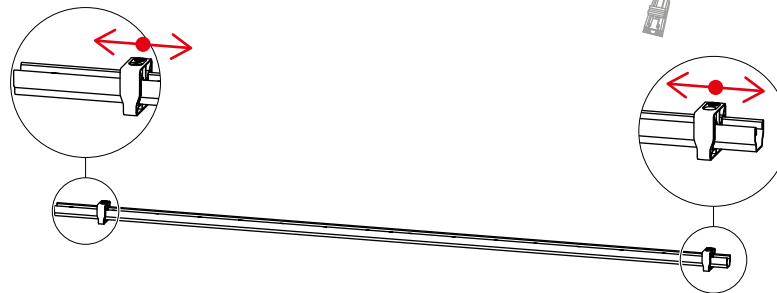

**10** 2003145  
Climber Set

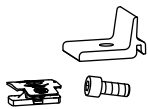

**11** 2004413  
SingleRail Light 36

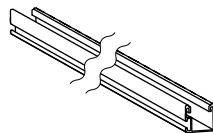

2002870  
Cable-Manager

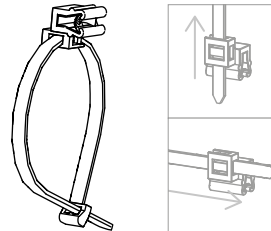

**12** 2001976  
SingleRail 36 Con-  
nector Set

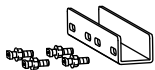

**13** DomeClamp EC



2003542  
TerraGrif K2MI  
Duo 18

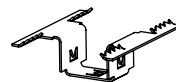

2004141  
Mat S Tool

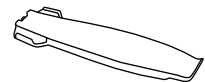

# Components

## Ballast

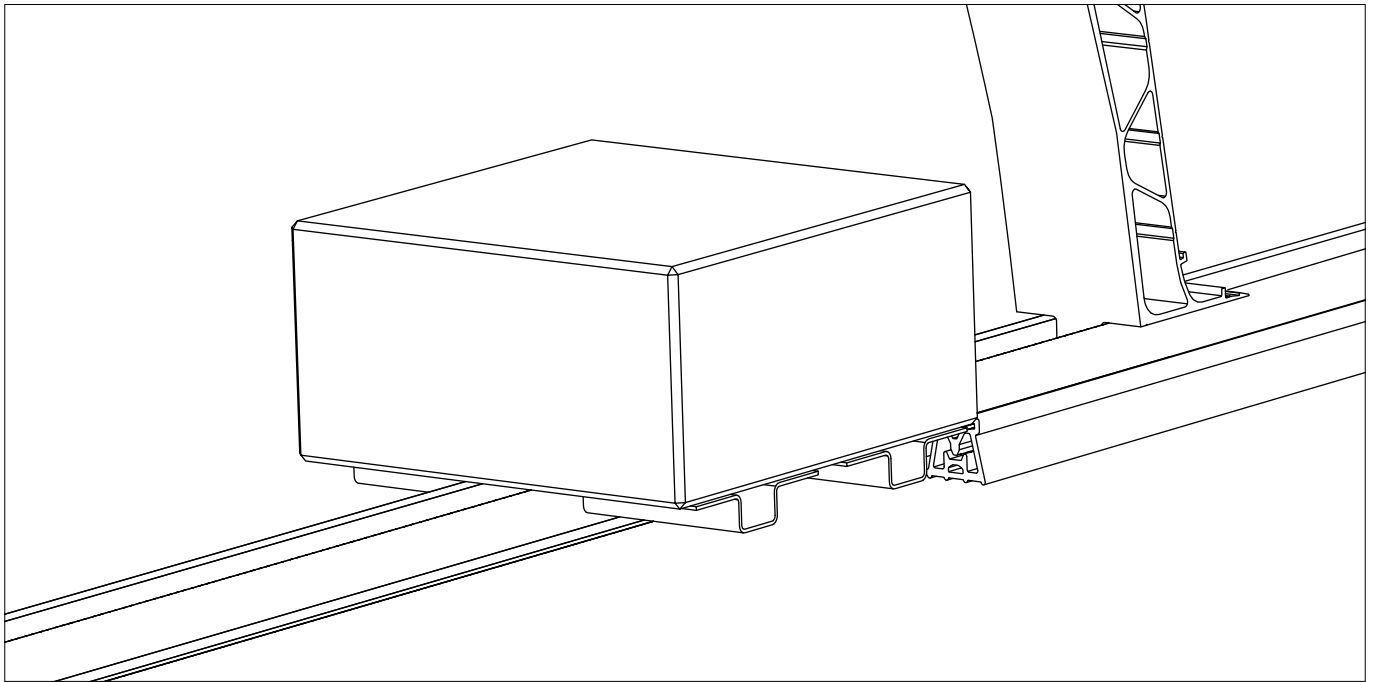

2002300  
**SpeedPorter**

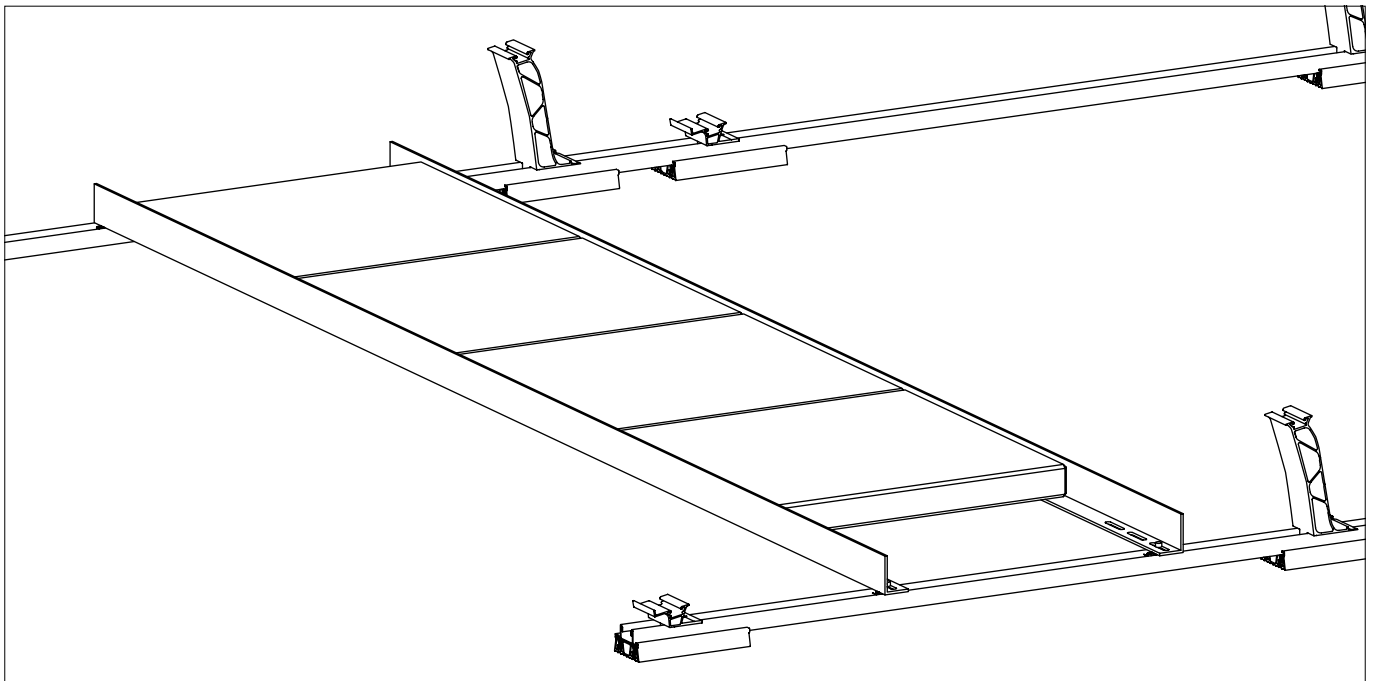
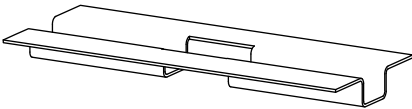

2004157  
**Porter Flex**

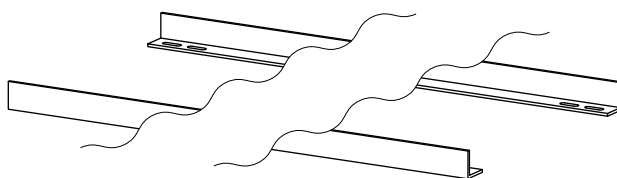

1001643 + 2001729  
**MK2 Slot nut with clip +  
Allen bolt M8×20**



## Fixed connection to the roof

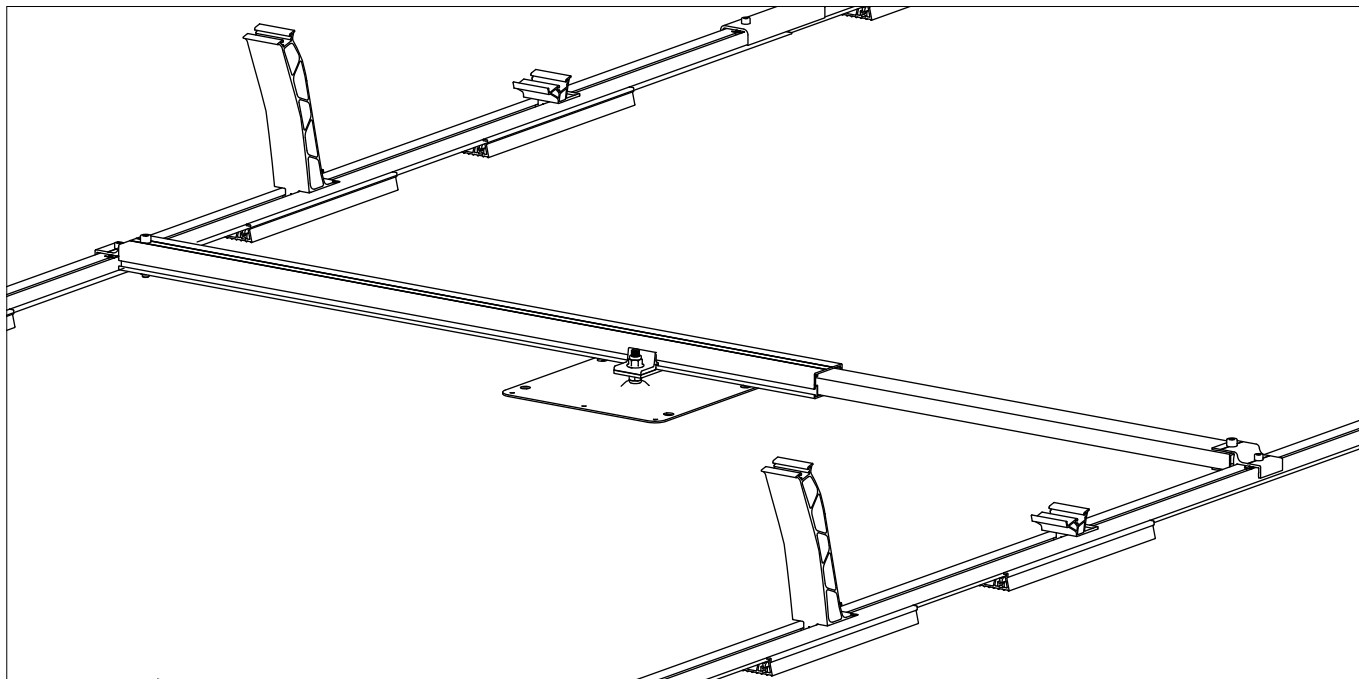

- 1** 2003384  
**Dome FixPro S**
- 2** 2002546 / 2002547  
**Adapter plate M10/12**
- 3** 2003146 / 2003147  
**Climber M10/12**

- 4** **Roof anchor plate**  
Not included in the K2 product portfolio.  
Other fastening elements (e.g. screws and nuts) for fixing to the fastener must be provided by the customer.

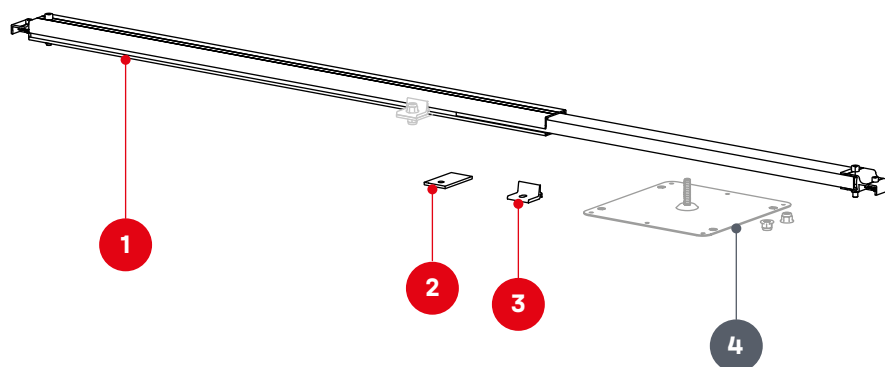

# Assembly

## Installation of module field and thermal separations

**!** The minimum assembly values ( $S_{x1}/S_{y1}$ ) for the thermal separations of module blocks must not be undercut. In K2 Base, you set the distances between the module edges ( $S_{x2}/S_{y2}$ ) for planning. The K2 Base mounting plan outputs the automatically calculated mounting values depending on  $S_{x2}/S_{y2}$ .

The diagram illustrates the installation of module blocks in a field. It shows a grid of modules with dimensions  $S_{x1}$  and  $S_{y1}$  for the thermal separations, and  $S_{x2}$  and  $S_{y2}$  for the module edges. The maximum height of the field is indicated as  $\text{max. } 12.3 \text{ m}$ . A circular inset provides a detailed view of the thermal separation between module blocks, showing a dimension of  $\leq 18 \text{ mm}$ .

**1**

**!** To measure the distances between mounting rails, set Dome Speed Spacer to the distance  $D_R$ .

The diagram shows a module with length  $L_M$  and a Dome Speed Spacer. The distance between mounting rails is  $D_R = (0.5 \times L_M) - 15.5 \text{ mm}$ . A circular inset shows the spacer being rotated to measure the distance between mounting rails.

2

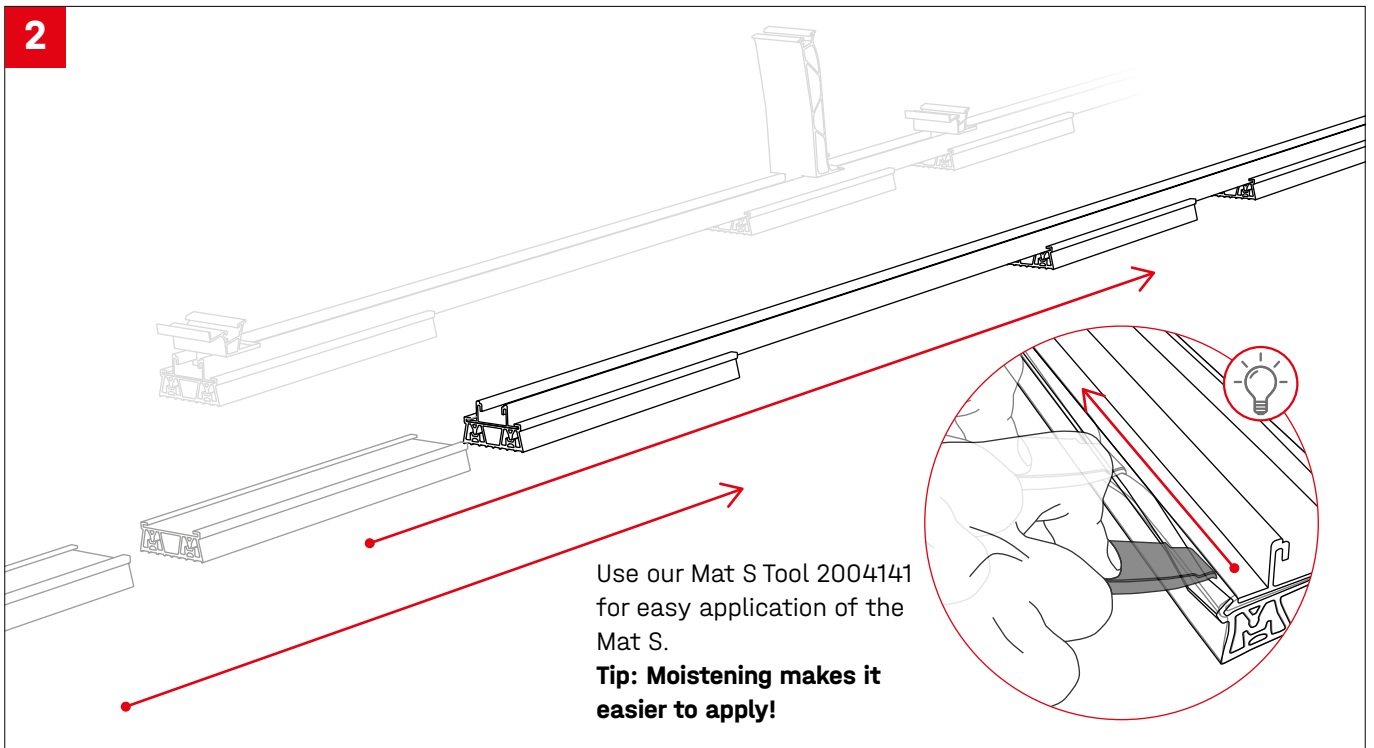

3

! 16 Nm

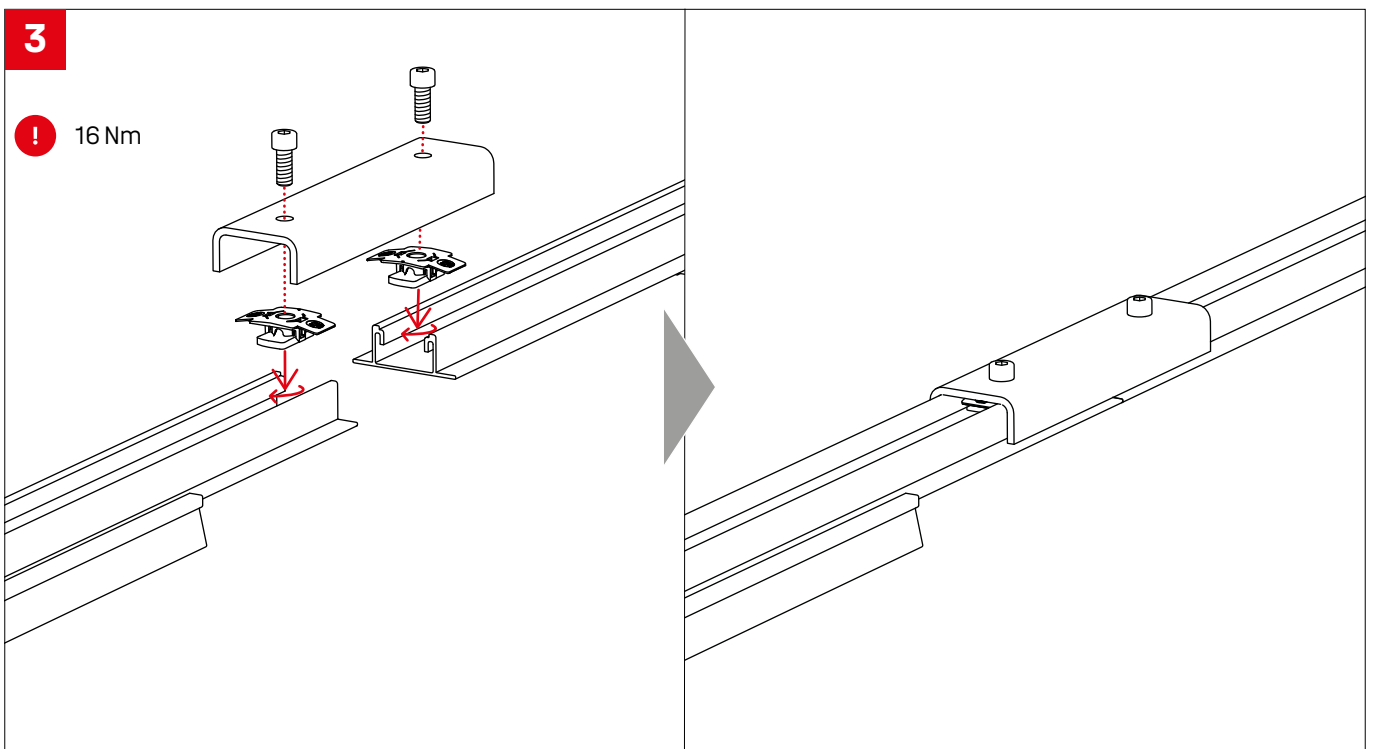

4

! Place the rail types according to the Base installation plan.

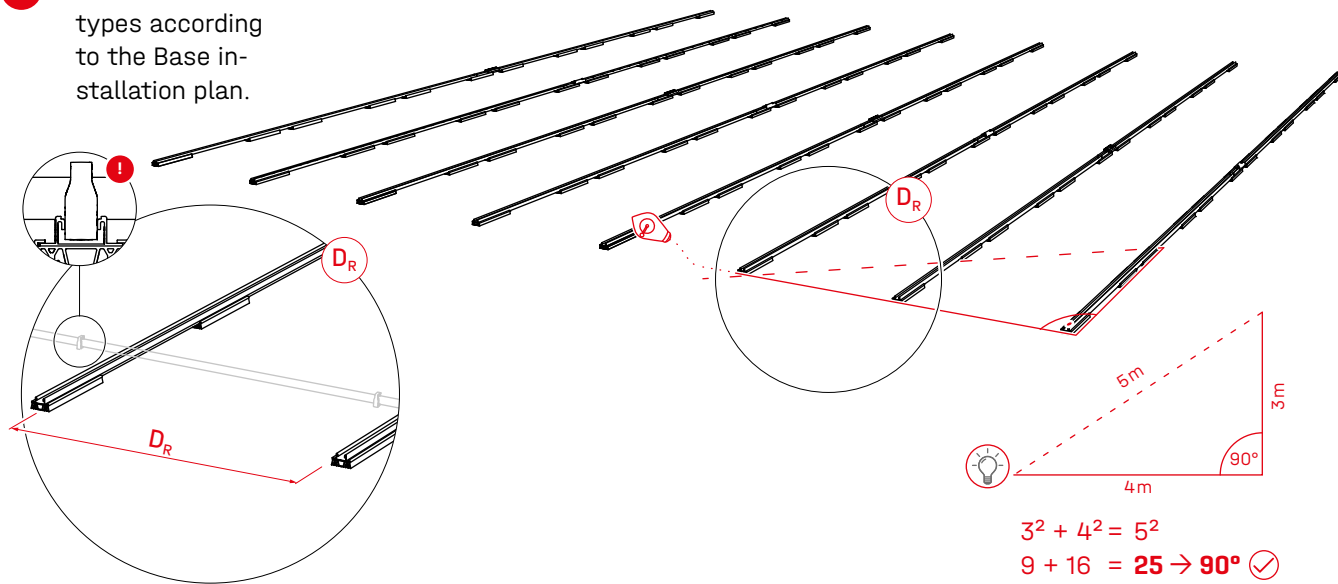

5

! K2 Base automatically calculates the pre-assembly dimensions  $M_1 / M_2$  and outputs them in the assembly plan. These must be adhered to during assembly.

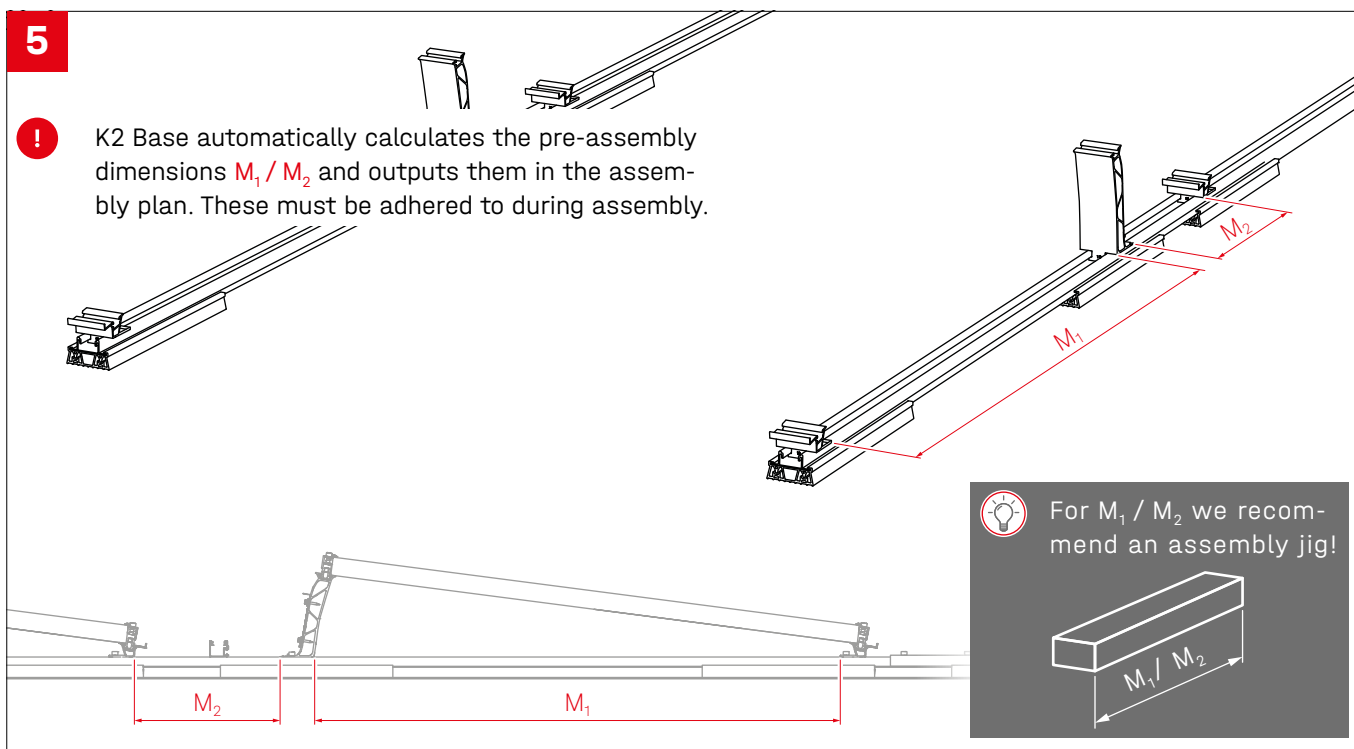

6a

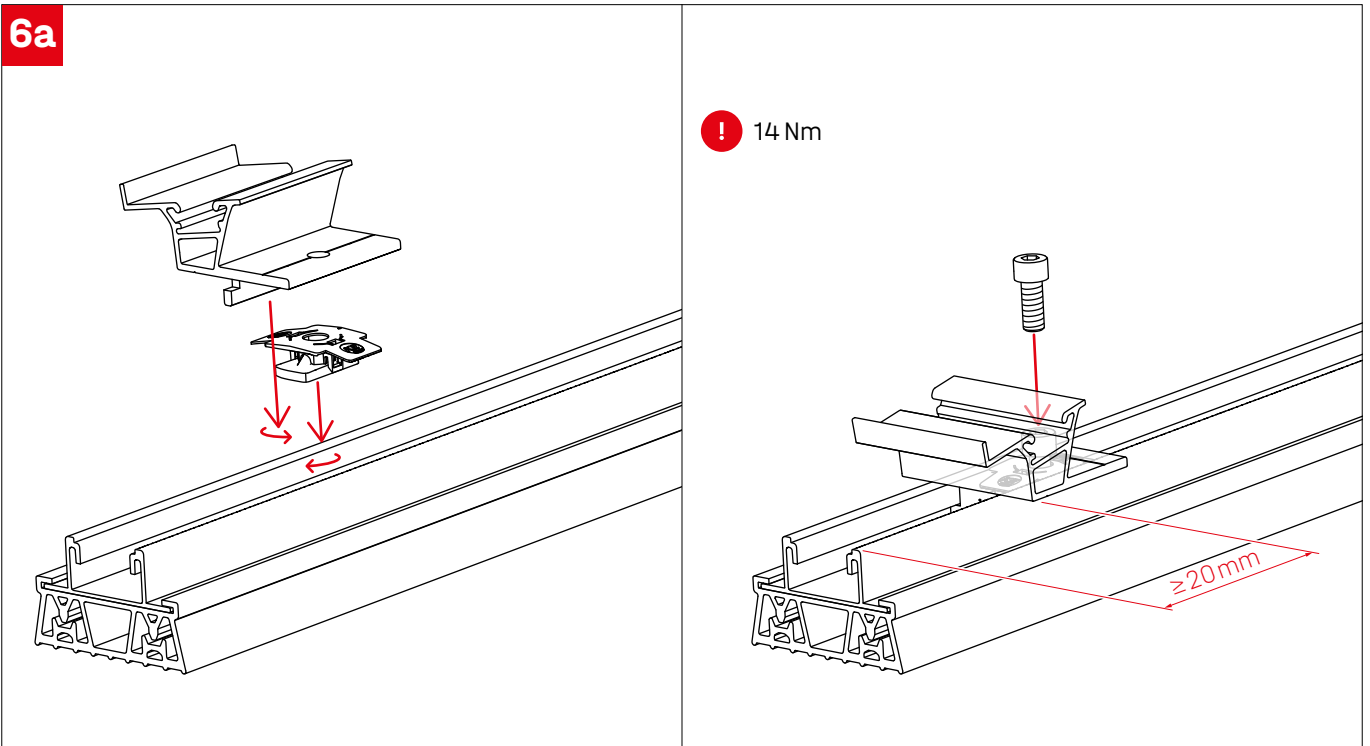

6b

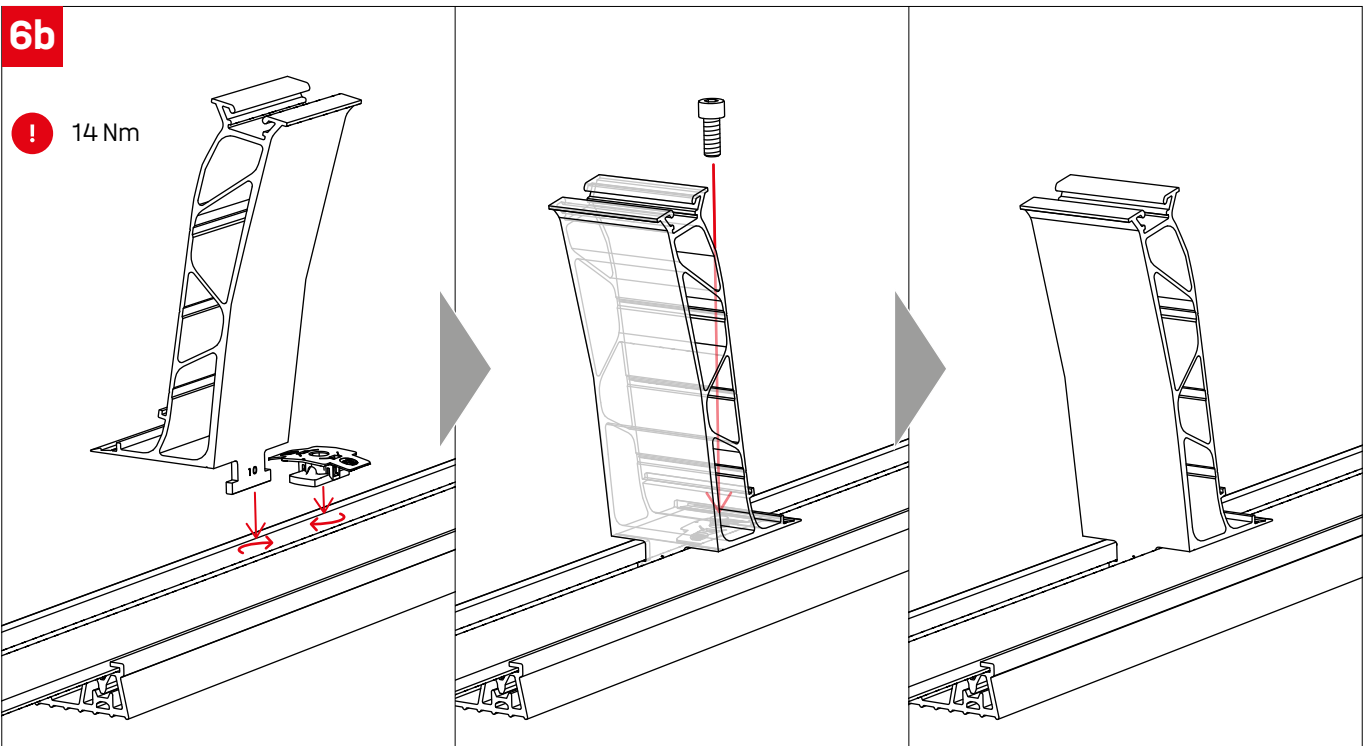

# 7a



The K2 Base assembly plan (right) shows in orange where row connections with SingleRail Light are to be placed.

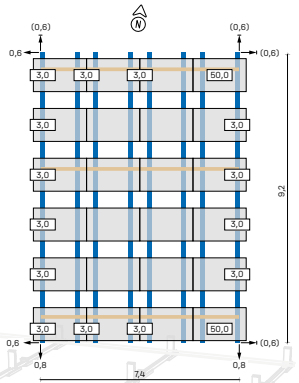
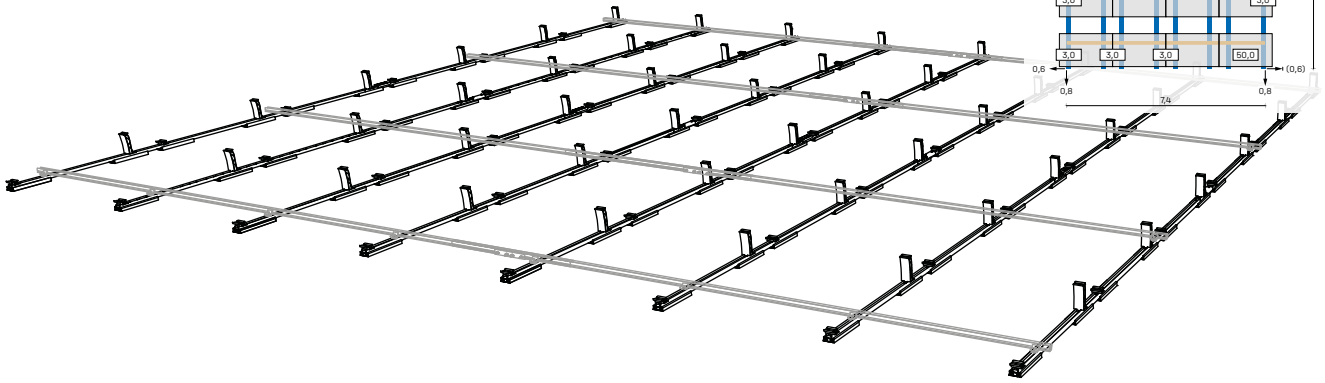

# 7b



16 Nm

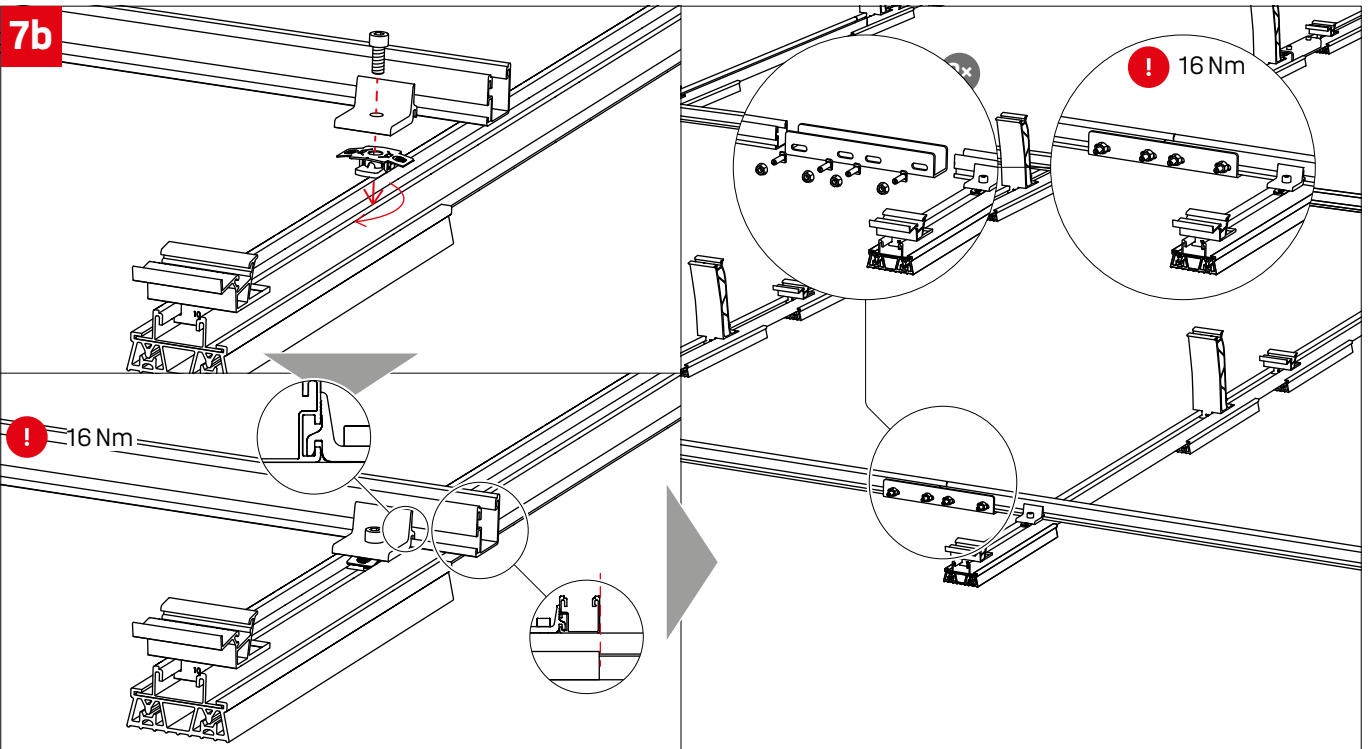

8

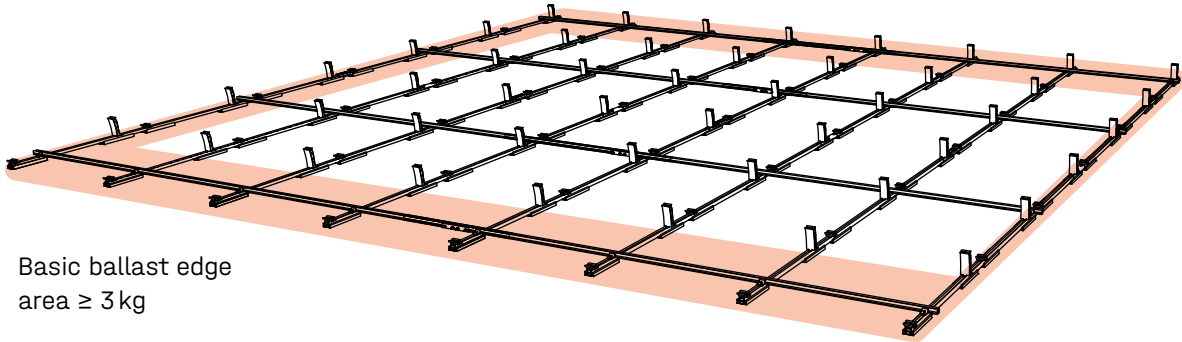

! Basic ballast edge  
area  $\geq 3$  kg

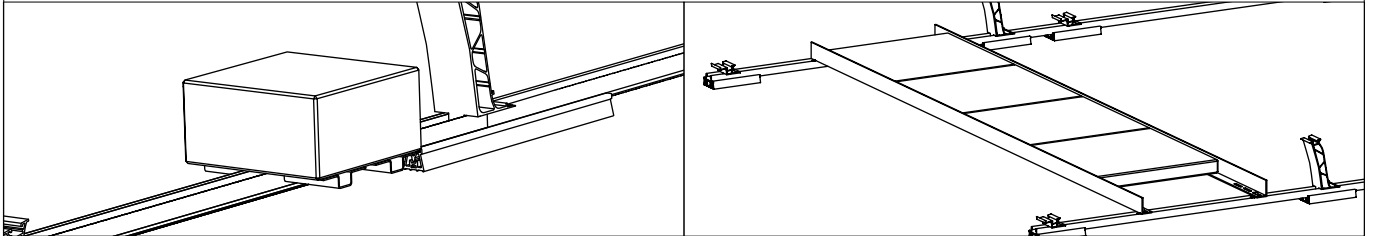

## Module assembly

1

! 14 Nm

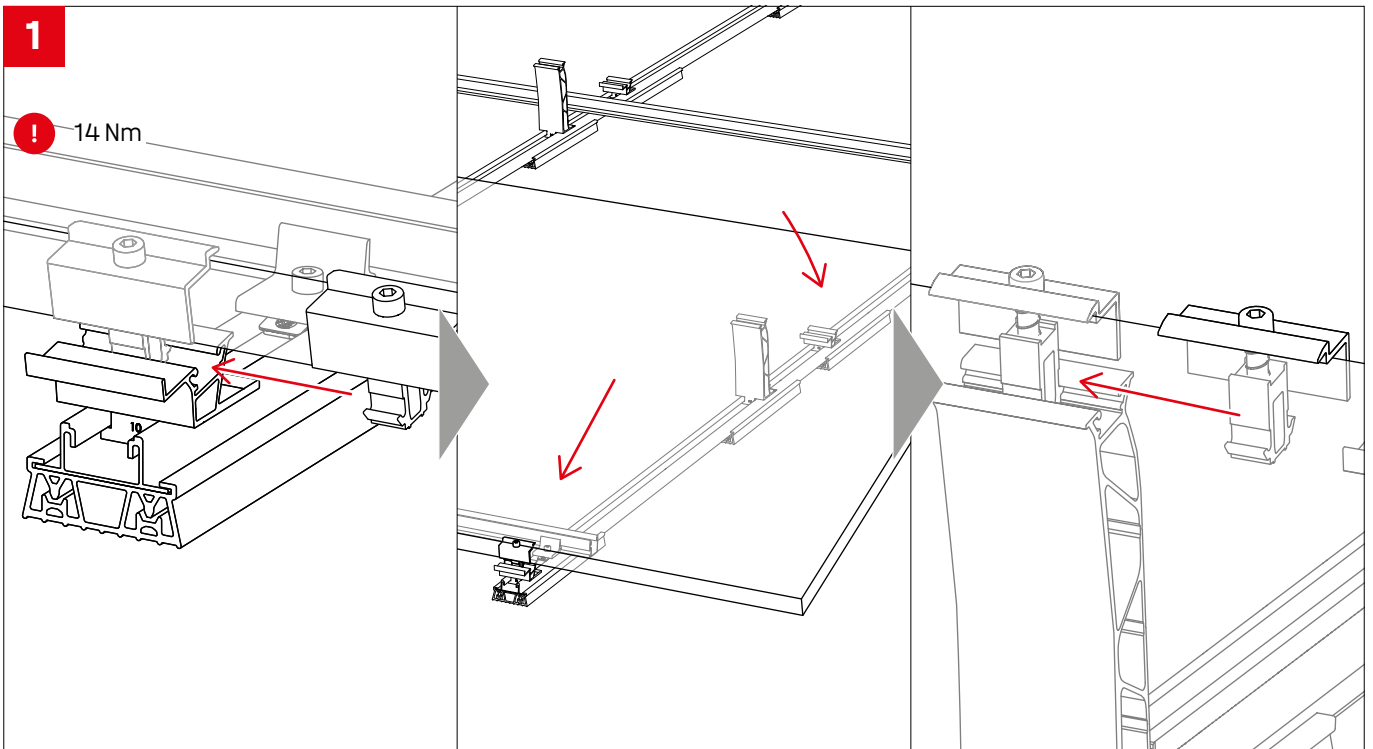

2

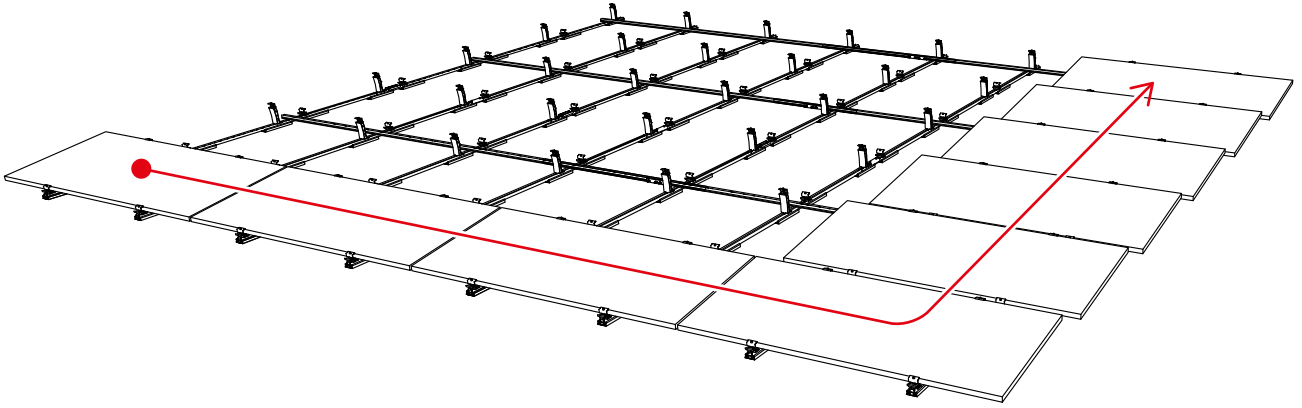

3

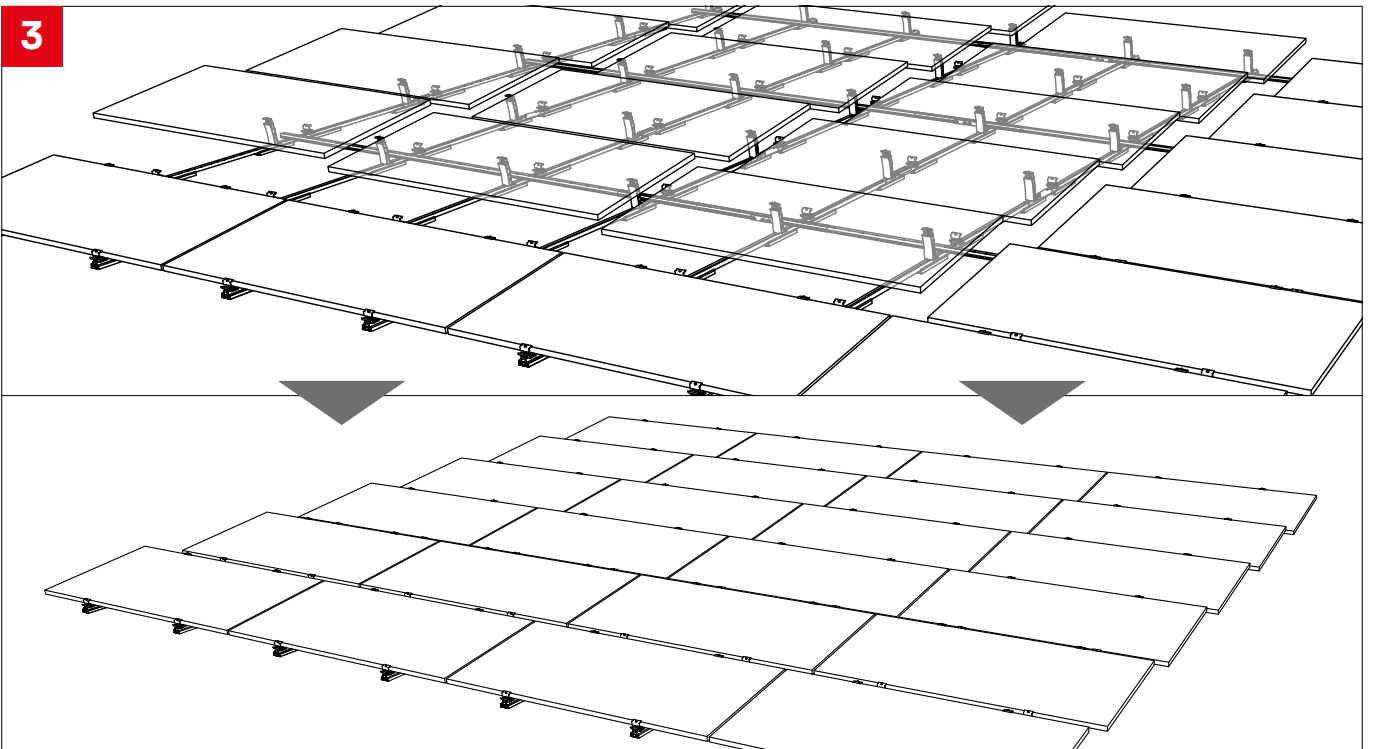

## Assembly Windbreaker

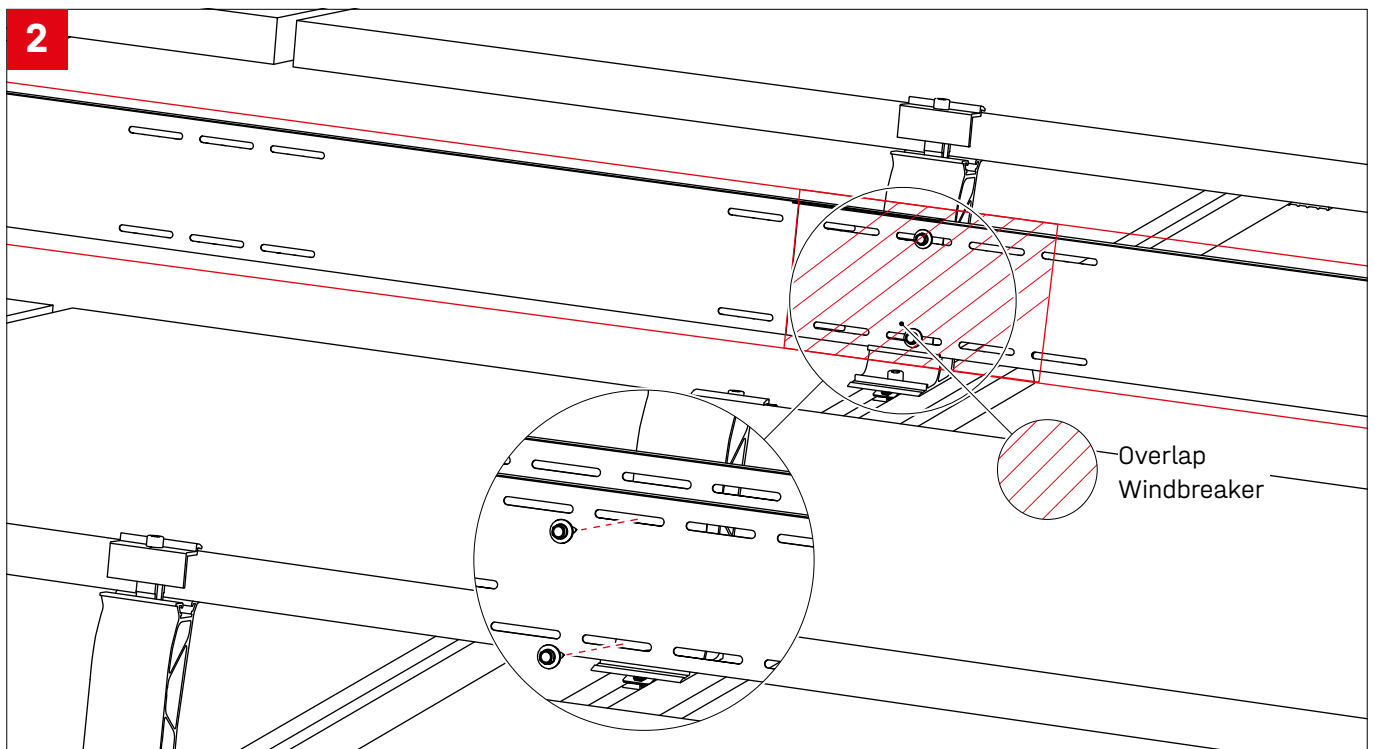
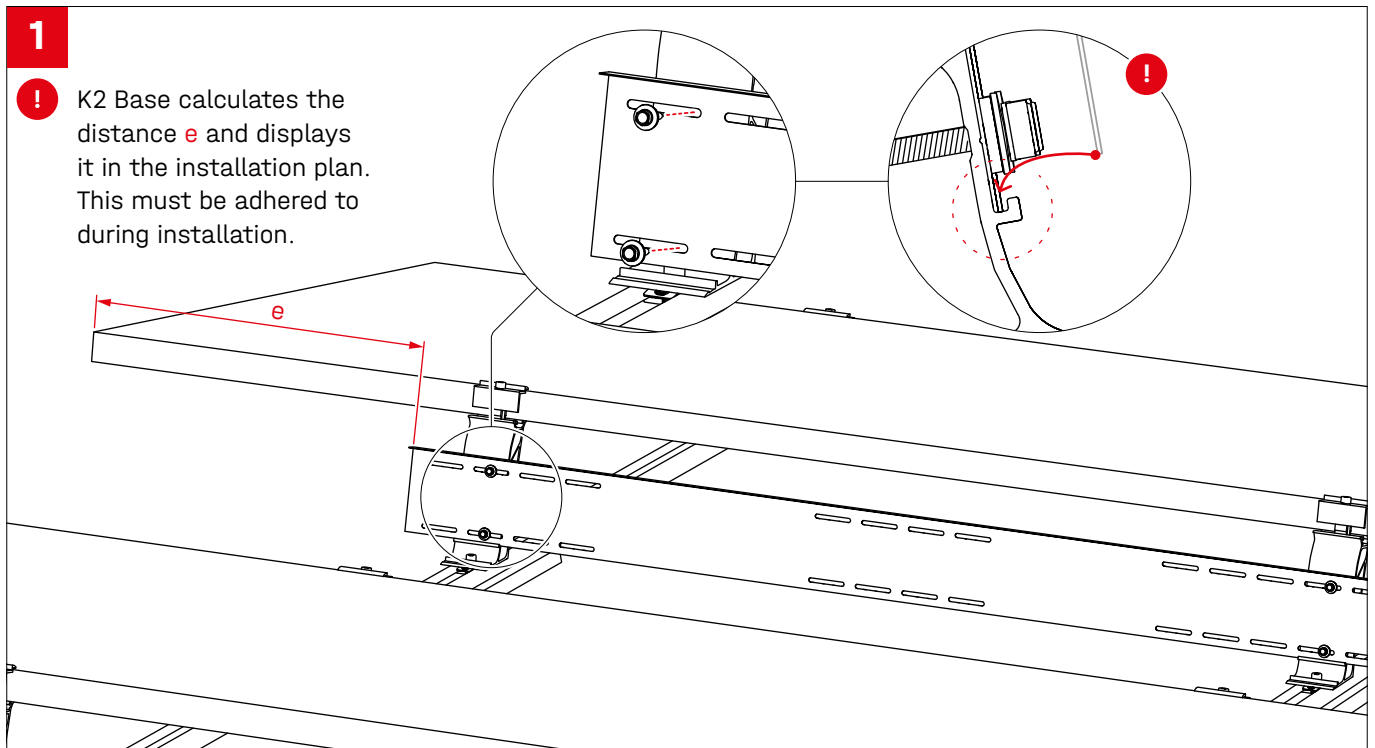

## Ballasting options and specifications

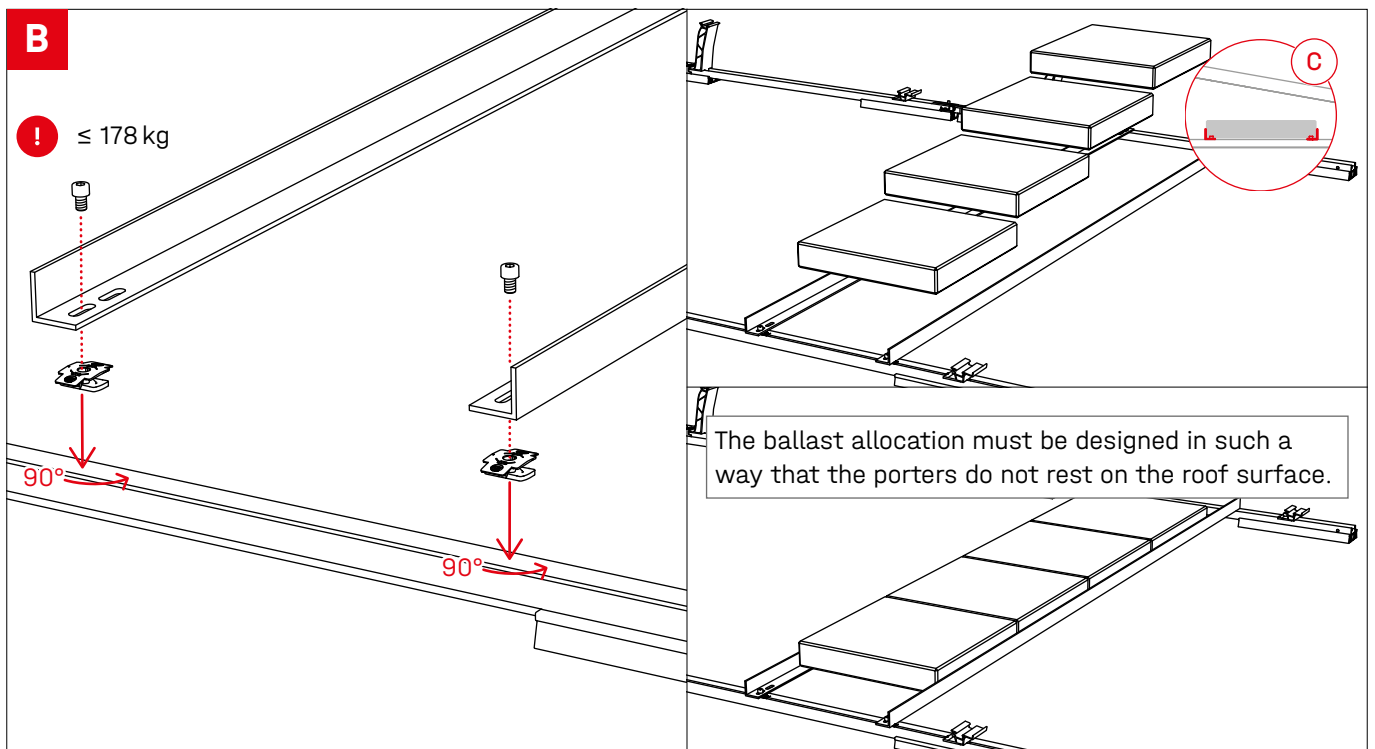
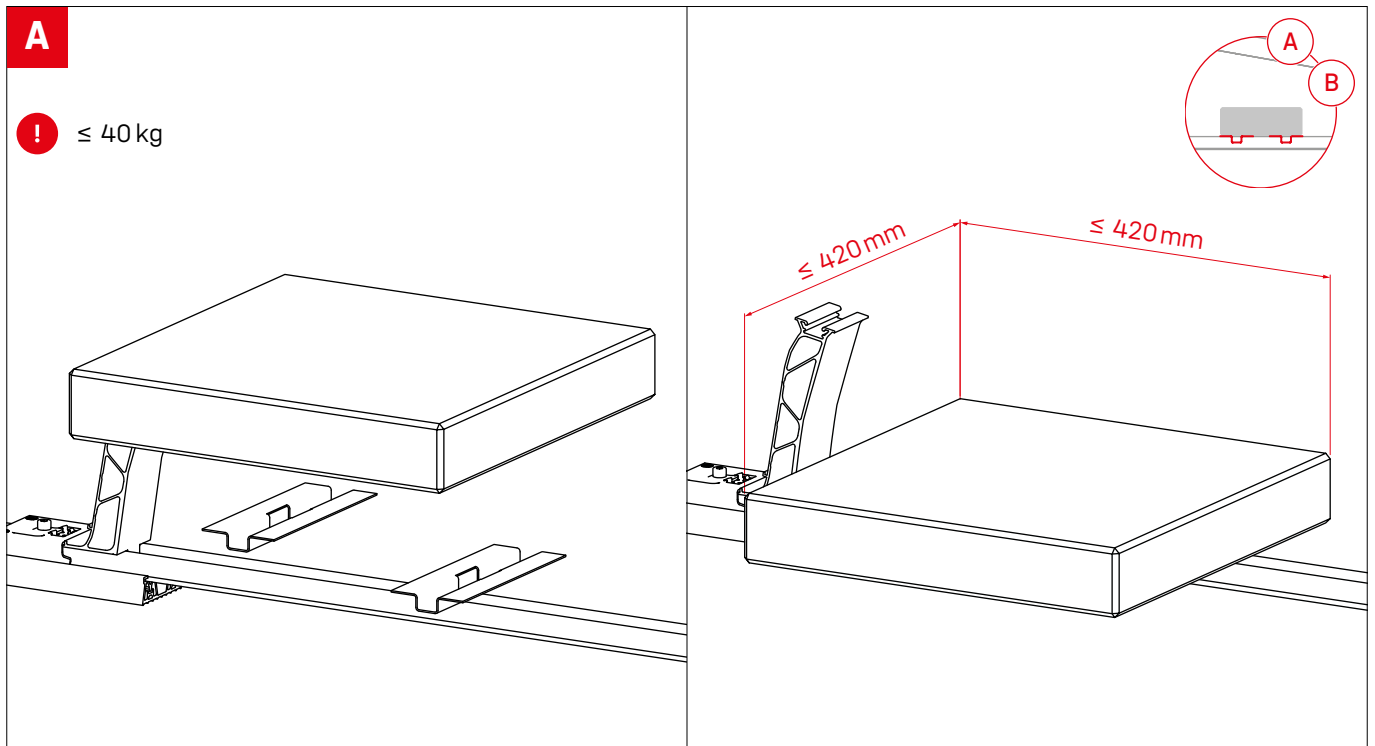

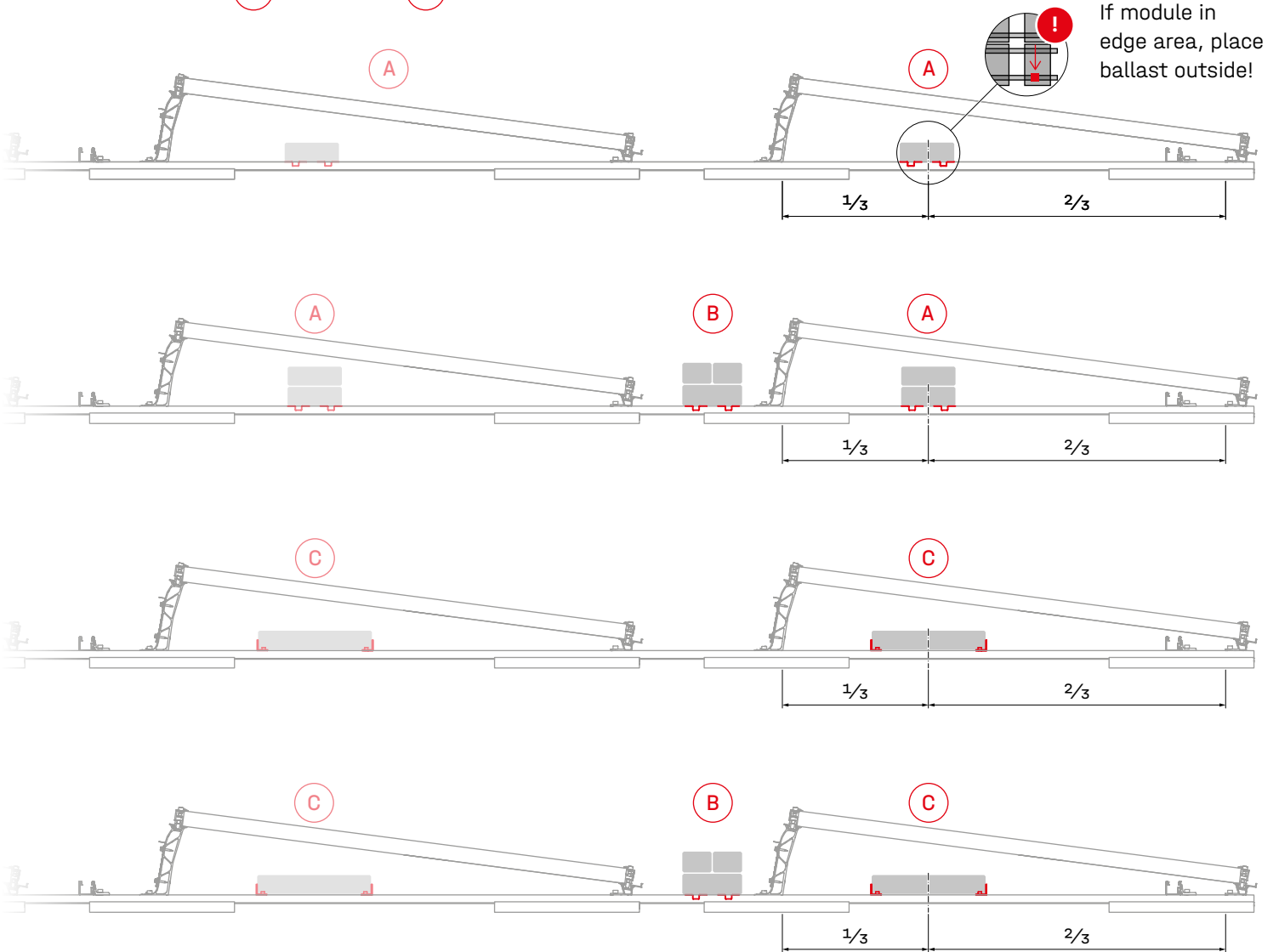
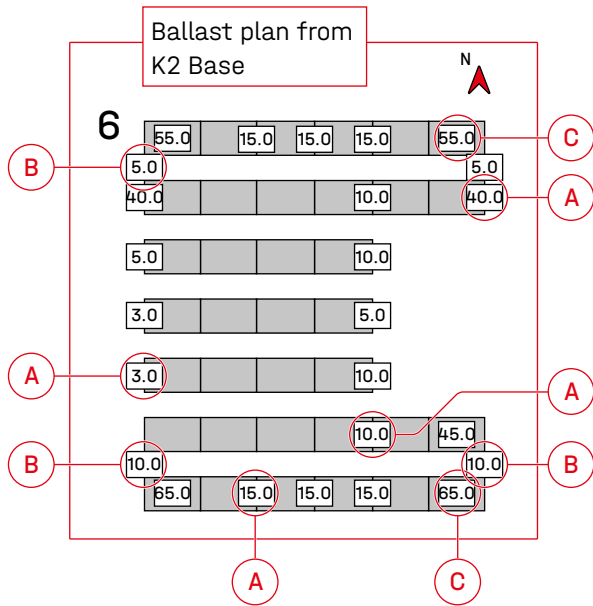

# Optional assembly steps

## Fixed connection with Dome FixPro using Solmont mounting base

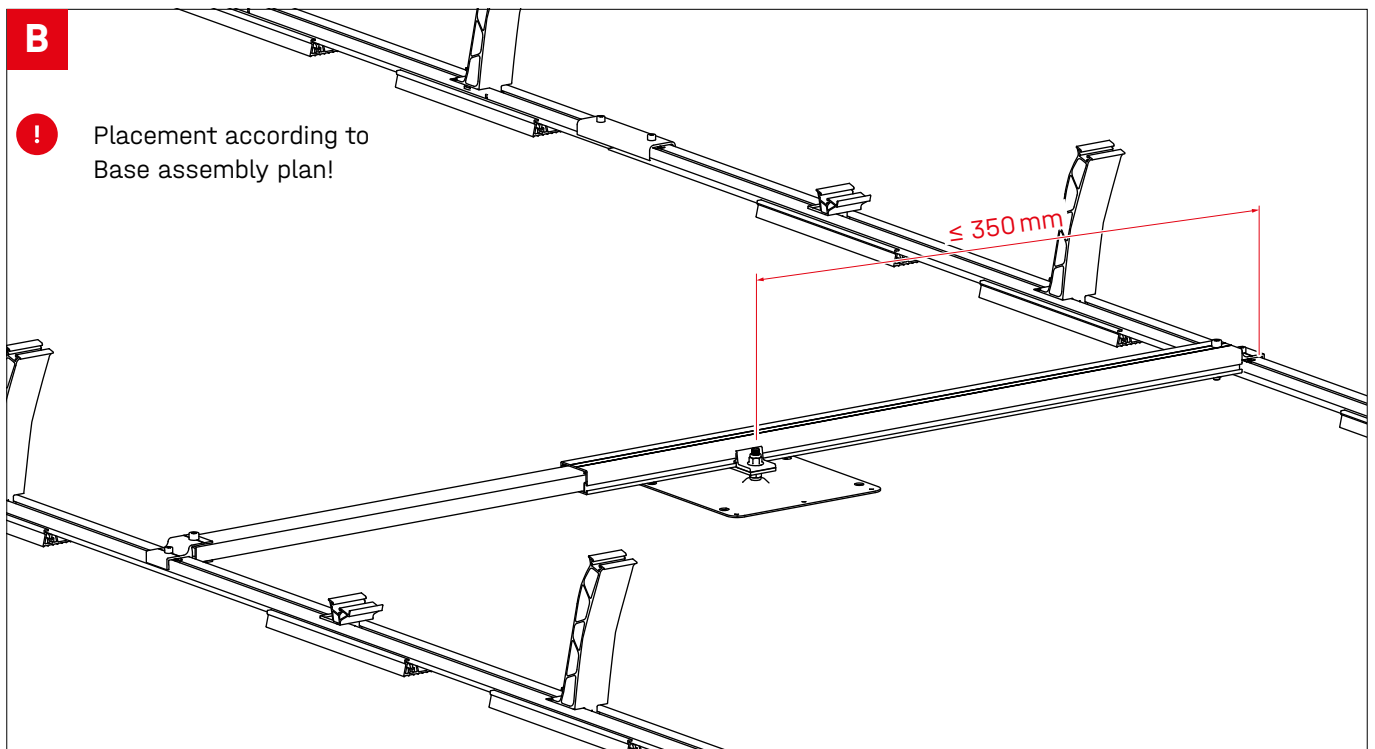
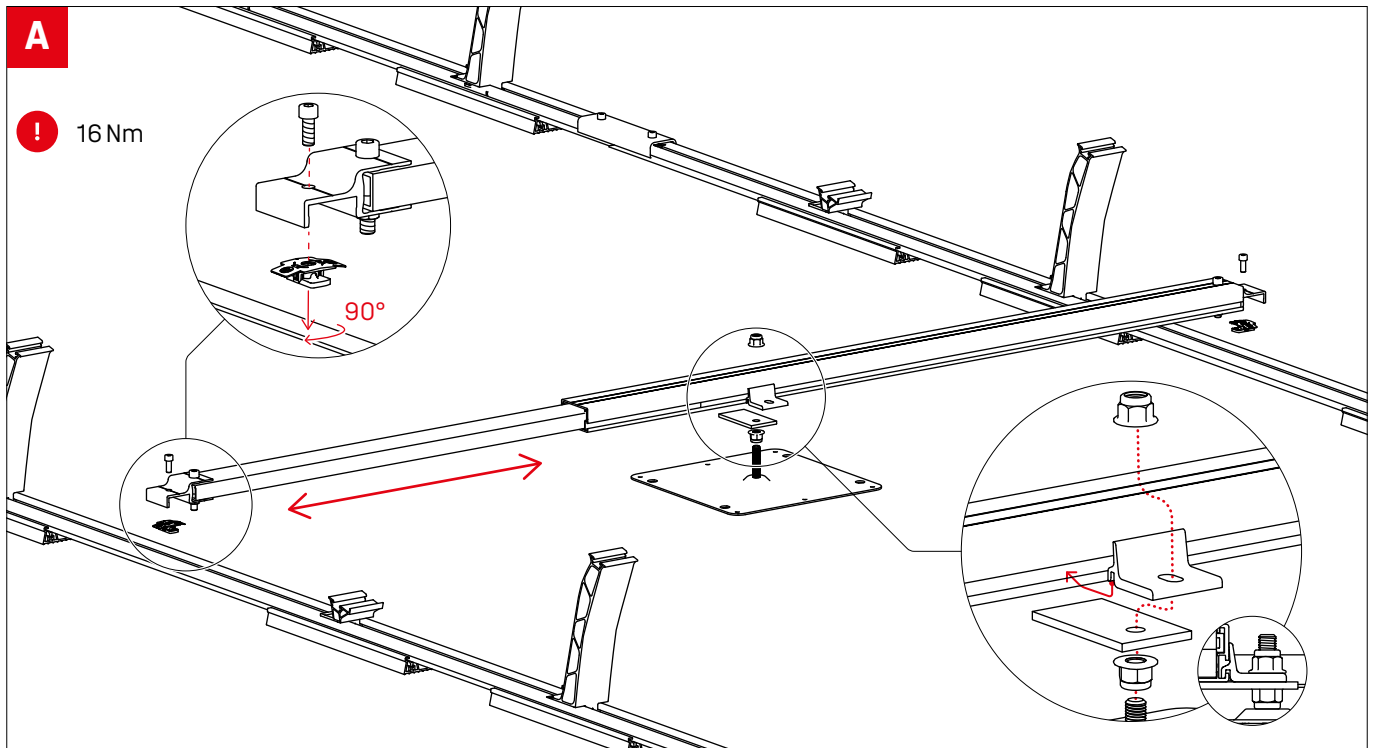

## Cable-Manager

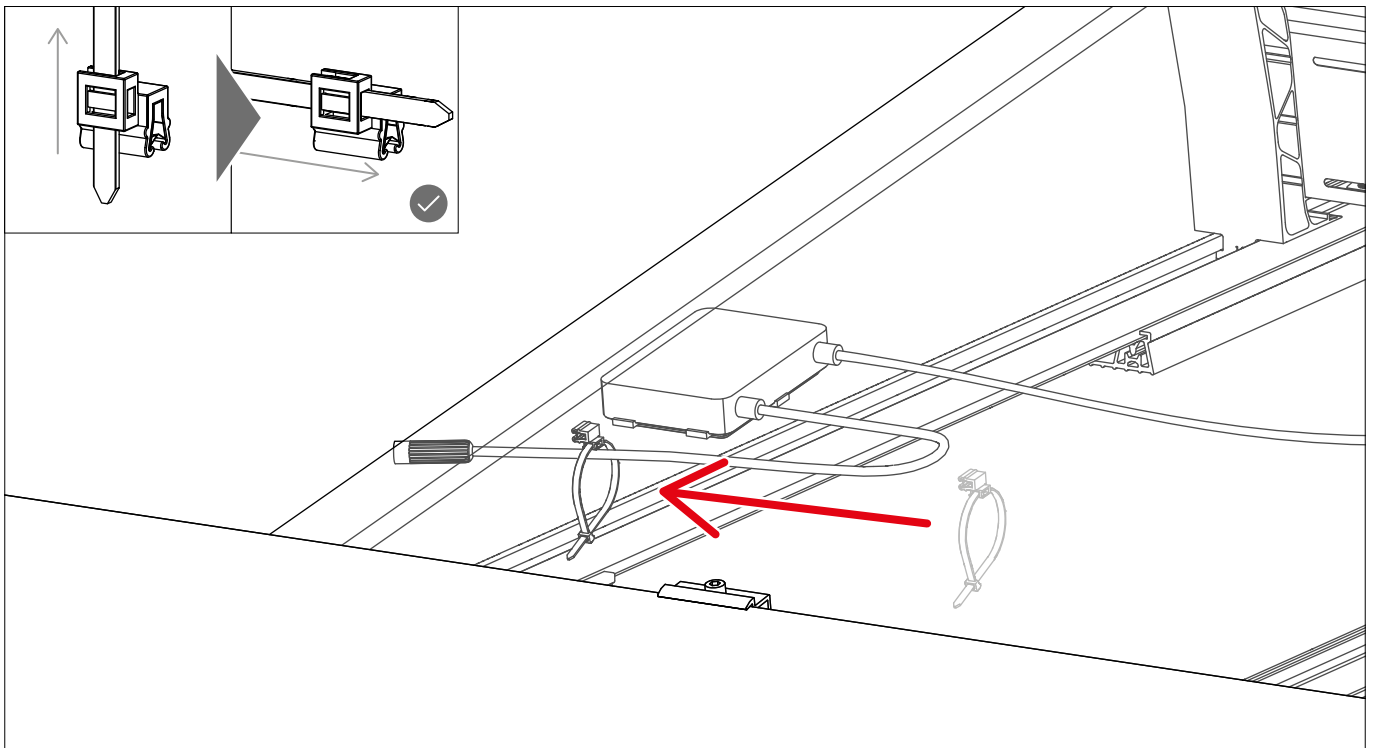

## Module frame earthing with TerraGrif K2MI

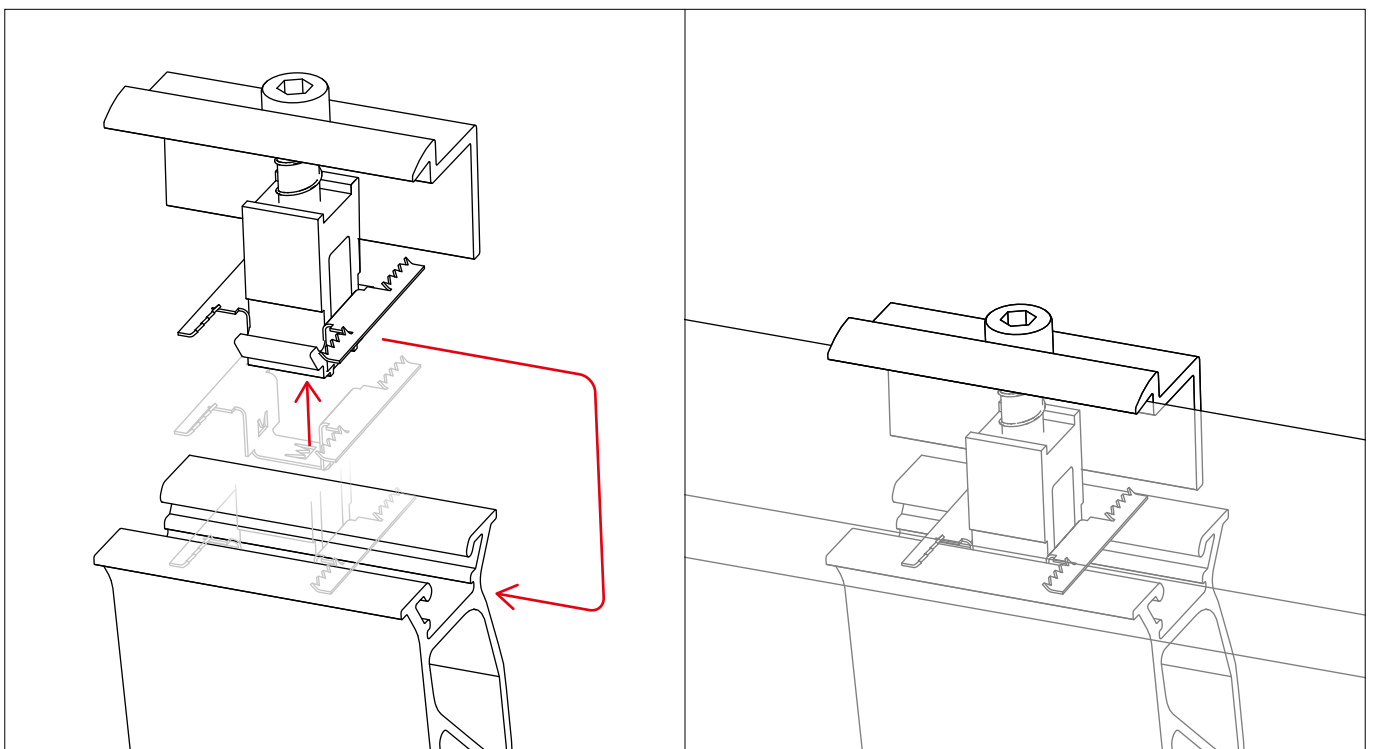

# Notes







# Connecting Strength

## Thank you for choosing a K2 mounting system.

Systems from K2 Systems are quick and easy to install. We hope these instructions have helped. Please contact us with any questions or suggestions for improvement.

Our contact data:

- [k2-systems.com/en/contact](https://k2-systems.com/en/contact)
- **Service Hotline: +49 (0)7159 42059-0**

Our General Terms of Business apply. Please refer: [k2-systems.com](https://k2-systems.com)

### K2 Systems GmbH

Haldenstraße 1 · 71272 Renningen · Germany  
+49 (0) 7159 - 42059 - 0 · [info@k2-systems.com](mailto:info@k2-systems.com) · [k2-systems.com](https://k2-systems.com)

S-Dome 6 Classic LS Assembly EN V4 | 0426 · Subject to change  
Product illustrations are exemplary and may differ from the original.