



**Connecting Strength**



K2 Systems Recommendation

# **Load distribution on flat roofs**

**Solutions for Dome 6 and Dome Zero mounting systems**

# Content

• <b>Introduction</b>	<b>3</b>
· Reference values from the K2 Base project report	3
· Scenarios with Dome 6 solutions	4
· Area comparisons of systems and solutions	5
• <b>Optimisation of load distribution</b>	<b>6</b>
· <b>Placement patterns with additional Mat S</b>	<b>6</b>
· Dome 6 Xpress	6
· Dome 6 Classic	7
· Dome 6 Classic LS	8
· Dome Zero	9
· <b>Enlargement of the contact surface with LoadSolver</b>	<b>10</b>
• <b>Notes</b>	<b>11</b>

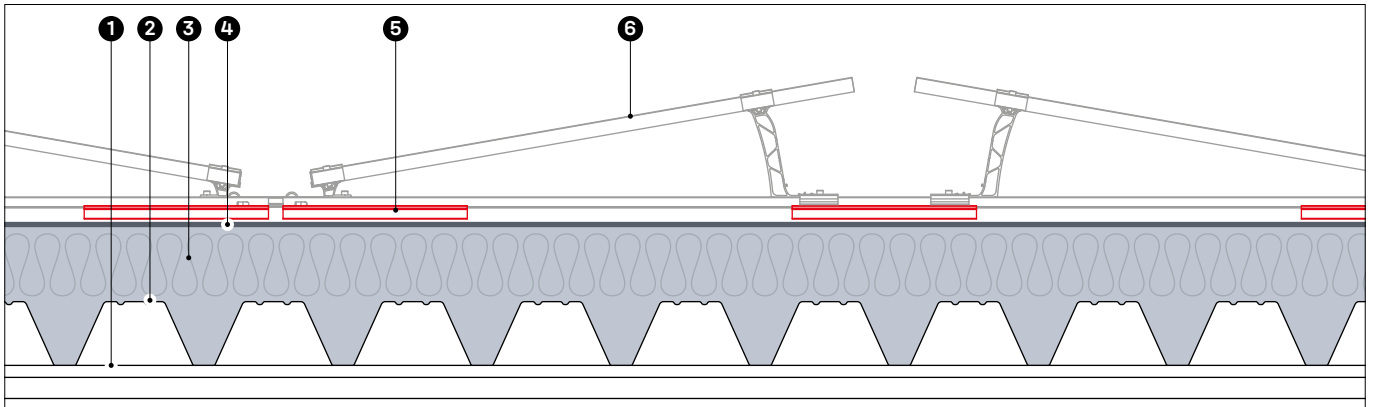

Illustration of roof structure: ① building support structure · ② trapezoidal sheet metal · ③ thermal insulation · ④ roofing · ⑤ support surface for load distribution · ⑥ PV module

**With the construction of a PV system on a flat roof, additional load is added to the roof and the distribution of snow load is changed.**

This change depends on local conditions, such as wind and snow loads, the building itself and the planned PV system.

K2 Systems recommends taking the additional load into account in the roof substructure, the installed thermal insulation and the roofing. In addition, the condition of the roofing and insulation must be checked by experts to ensure that it is in a suitable condition before construction.

The properties of the roofing differ, but the age or type of construction also play a decisive role.

### Options for optimising load distribution

One important factor is snow, which is distributed differently on the flat roof of a ballasted PV system, meaning that the resulting forces are applied via the contact points. Therefore, check all relevant entries in K2 Base.

Compare the reference values from the project report with the permissible continuous compressive stress of the thermal insulation manufacturer. Please refer to the technical data of the manufacturer or manufacturer associations for the permissible continuous pressure load. If the pressure load is exceeded, distribute the superimposed load over larger areas. By increasing the area, the system load can be introduced more homogeneously into the thermal insulation. To do this, you can select the 'Additional Mat S' option in the 'Results' tab.

## Reference values from the K2 Base project report

dead load system	$q_{system} = 0.12 \text{ kN/m}^2$	
aerodynamic coefficient	$C_{p,pressure} = 0.20$	
<b>Load distribution underneath the building protection mat under Peak (45°)</b>		
Dimensions	$75.3 \times 380.0 \times 23.1 \text{ mm}$	
	$A_{mat} = 28,614.00 \text{ mm}^2$	
	$A_{load \text{ range area}} = 2.00 \text{ m}^2$	
maximum ballast	$G_{ballast \text{ required}} = 22.1 \text{ kg}$	
<b>Load distribution underneath the building protection mat under SD (45°)</b>		
Dimensions	$75.3 \times 380.0 \times 23.1 \text{ mm}$	
	$A_{mat} = 28,614.00 \text{ mm}^2$	
	$A_{load \text{ range area}} = 1.00 \text{ m}^2$	
maximum ballast	$G_{ballast \text{ required}} = 5.7 \text{ kg}$	
<b>Load Combinations</b>		
	$\sigma_{Pa, \text{heat insulation 00}} [\text{Pa}]$	$\sigma_{Pa, \text{heat insulation 01}} [\text{Pa}]$
Load case combination 00	15,632	5,979
Load case combination 01	80,815	38,571

The maximum actions (sum of dead load and snow load) on the roof covering (LCC01) can be found in the Structural Analysis report of the Base project report.

<b>Load Combinations</b>		
	$\sigma_{Pa, \text{heat insulation 00}} [\text{Pa}]$	$\sigma_{Pa, \text{heat insulation 01}} [\text{Pa}]$
Load case combination 00	10,421	3,986
Load case combination 01	53,877	25,457

The placement of additional Mat S under the SDs and Peaks reduces the surface pressure on the insulation significantly.

# Introduction

## Scenarios with Dome 6 solutions

### Dome 6 Xpress/Classic

In the standard Dome 6 Xpress & Classic systems, the PV modules are clamped at the corners on the short side of the modules. This ensures that the mounting rails are used optimally.

The load distribution contact surfaces are called Mat S and are placed under the Peak (upper mounting) and SD (lower mounting) elevation elements. The system weight and any ballast components transfer their own weight as well as wind and snow loads to these contact surfaces.

Depending on the project location, the properties and requirements of the thermal insulation, this solution may not be sufficient.

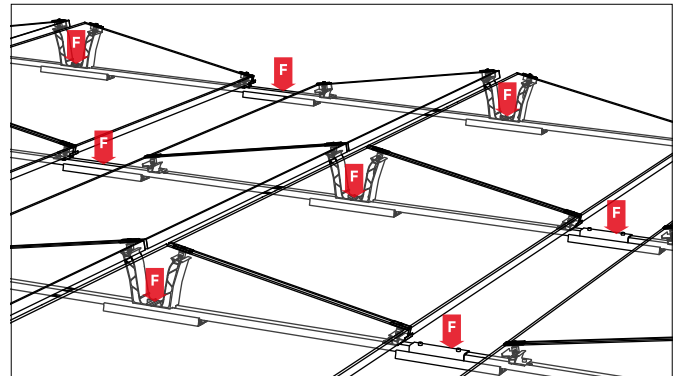

In the standard version, the D-Dome 6 Classic offers a Mat S as a support surface for the inner modules.

### Dome 6 Xpress/Classic with additional Mat S

Flat roof systems with Dome 6 Xpress or Classic can be equipped with additional Mat S to increase the load distribution contact area. With D-Dome Xpress, these are placed twice under Peaks, and with Classic, twice under SDs and Peaks. With S-Dome Xpress and Classic systems, additional mats are placed between Peaks and SDs.

This significantly increases the contact area for the determining loads and correspondingly reduces the pressure on the thermal insulation.

In many cases, this is a sufficient solution for protecting the thermal insulation from excessive loads.

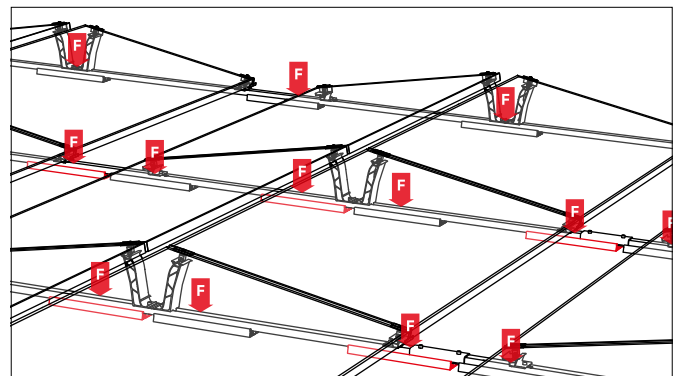

Additional Mat S pads for D-Dome 6 Classic and Xpress increase the contact area of the inner modules.

### Dome 6 Classic LS

The Classic LS system variant clamps the modules on the long side, approximately  $\frac{1}{4}$  (or  $\frac{1}{5}$ ) from the end of the module. Therefore, it is necessary to lay two mounting rails for each row of modules. Compared to the Xpress and Classic Systems, the LS requires more material.

The advantage of this is that the snow loads on the modules are better distributed across the roof. For load distribution on the insulation, there are automatically more contact surfaces, since for each mounting rail with Peaks and SDs the corresponding quantities of Mat S are added.

Overall the contact surface area for the LS system is significantly larger and so better distributes the loads onto the roof. There is also the option of placing more Mat S in the intermediate spaces to reduce the pressure further.

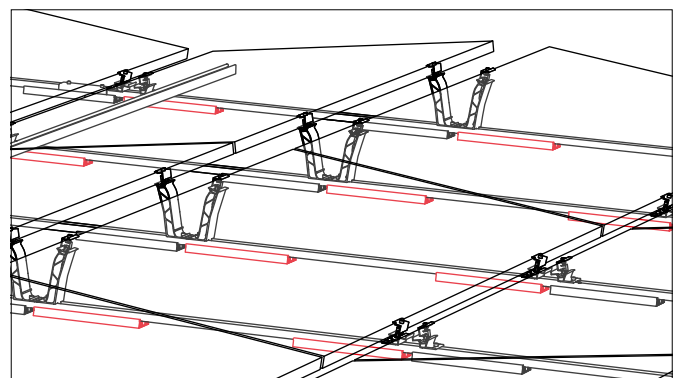

With D-Dome 6 Classic LS, the double mounting rails provide four Mat S as a support surface for each module - even in outer areas.

## Area comparisons of systems and solutions

The following table compares the load-inducing contact areas of D-Dome 6 systems in the inner area of a module block, which result from the use of Mat S. We use D-Dome 6 Classic at 100% as the standard case.

With additional Mat S, the contact surface area can be increased and thus values can be reduced approxi-

mately for respective Mat S by the corresponding factor for surface pressure.

The contact surface area in Classic LS systems is greater than Xpress and Classic systems and with additional Mat S, targeted results can be achieved for coverings with low permissible surface pressure.

D-Dome 6 variant	Contact area ( $\sigma$ Peak)	
	Standard assembly Mat S	Additional Mat S
Xpress	125%	200%
Classic	100%	200%
Classic LS	200%	400%

In the table, we consider a double module in the inner area of a module block, independently of the ballast.

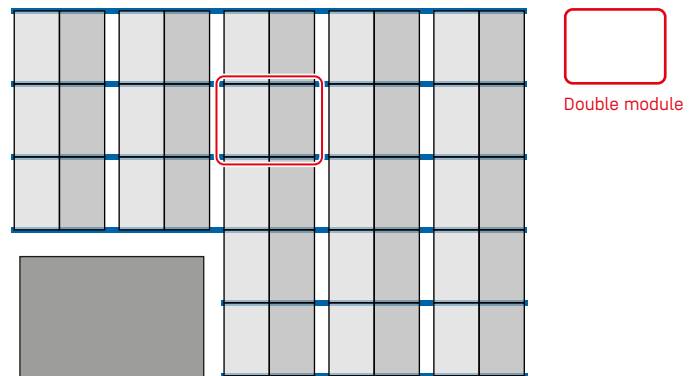

### Comparison of the use of Mat S surfaces

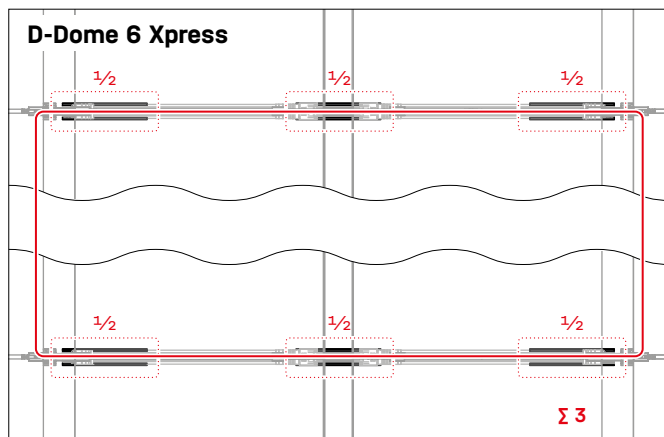

A double module in the inner module block has an area of  $3 \times$  Mat S.

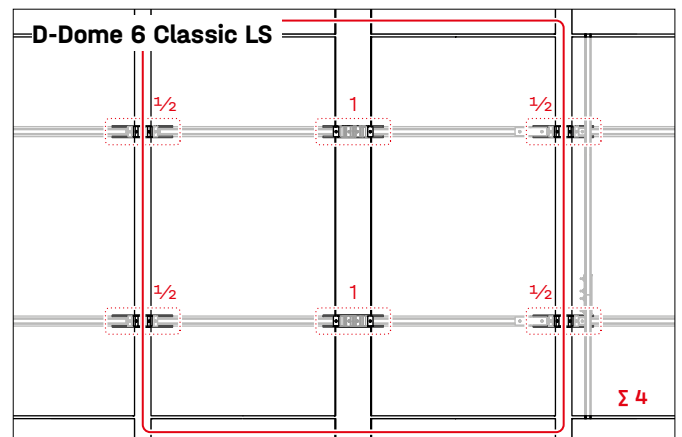

The double rails for modules in D-Dome 6 Classic LS have one more Mat S compared to Xpress.

# Optimisation of load distribution

## Placement patterns with additional Mat S

### Dome 6 Xpress

- The additional Mat S only needs to be added to the inner rails. See red areas in the illustration on the right.
- For D-Dome 6 Xpress, an additional Mat S is added under one Peak and the existing Mat S is repositioned under the other Peak
- For S-Dome 6 Xpress, an additional Mat S is added between each Peak and SD.

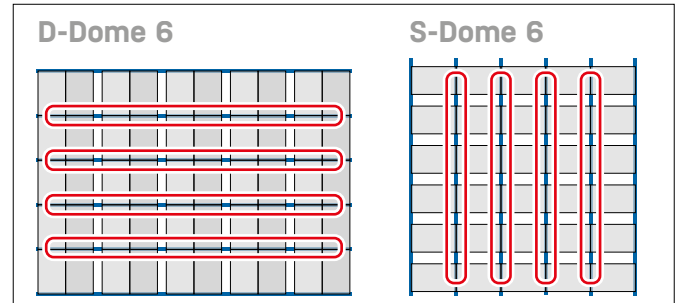

Placement areas in the module block under inner rails (blue)

### D-Dome 6 Xpress

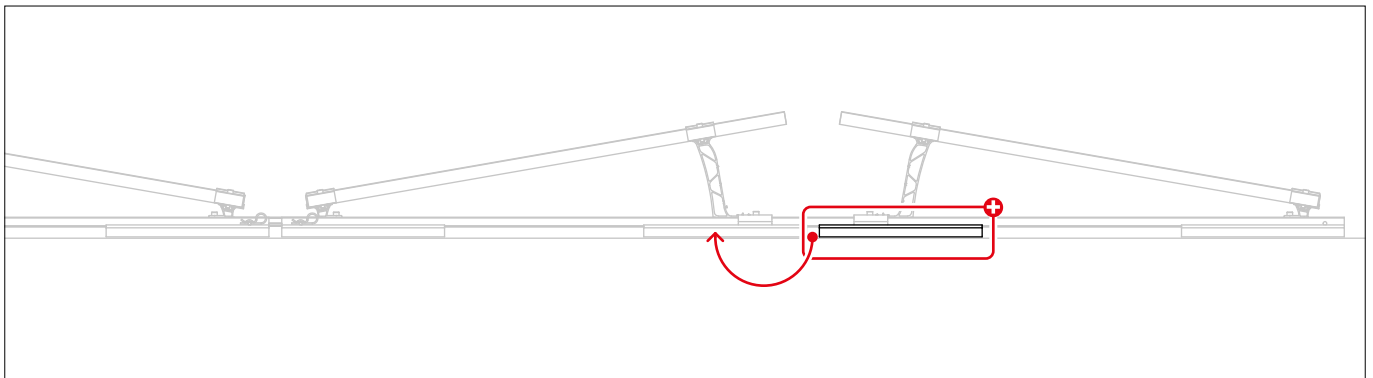

### S-Dome 6 Xpress

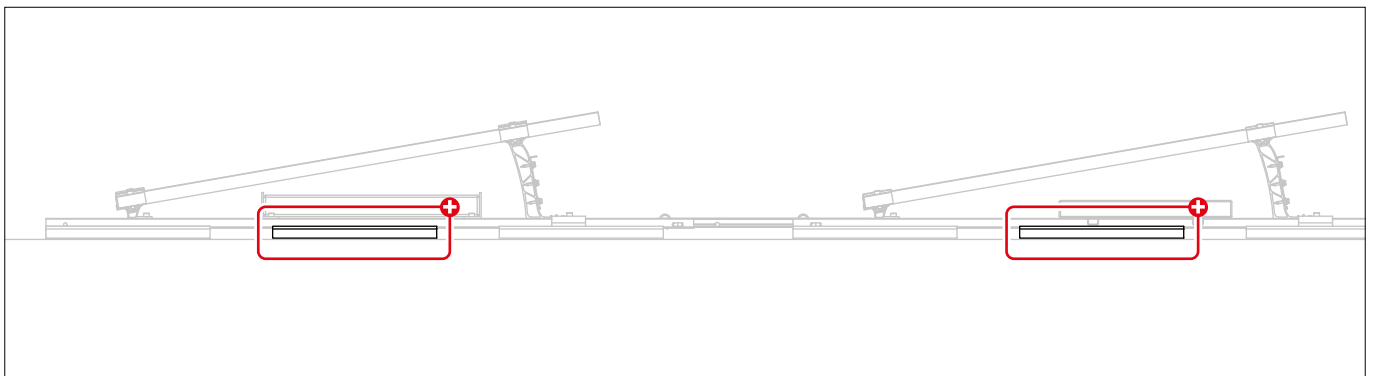

## Dome 6 Classic

- The additional Mat S only needs to be added to the inner rails. See red areas in the illustration on the right.
- For D-Dome 6 Classic, an additional Mat S is added under each of the peaks and SDs - not at rail ends.
- For S-Dome 6 Classic, an additional Mat S is added between each Peak and SD.

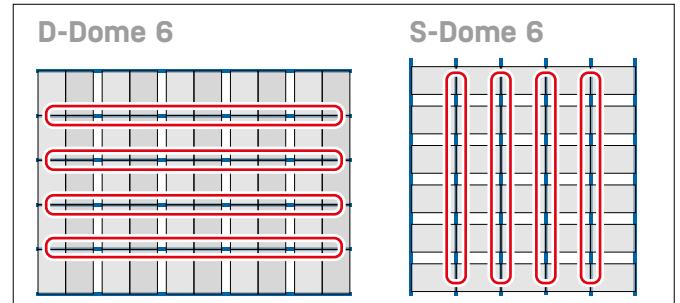

Placement areas in the module block under inner rails (blue)

### D-Dome 6 Classic

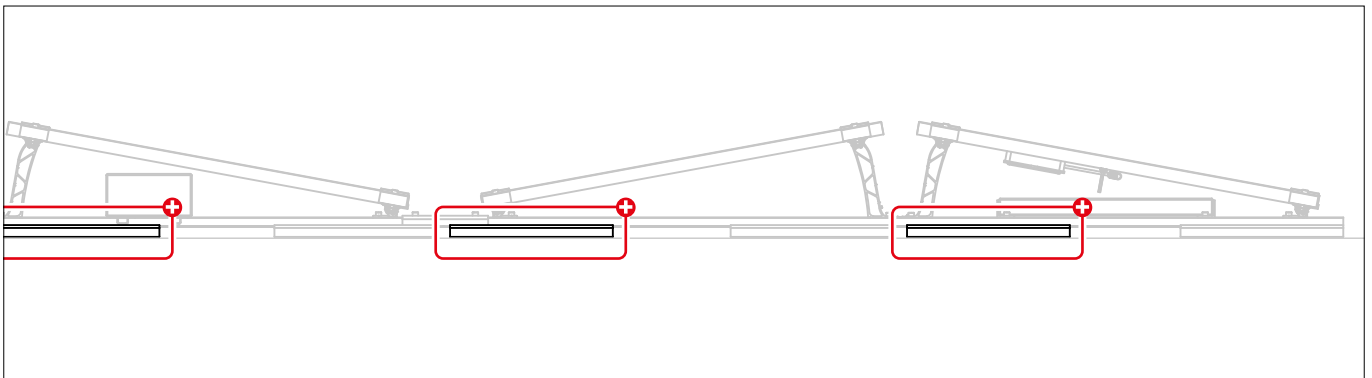

### S-Dome 6 Classic

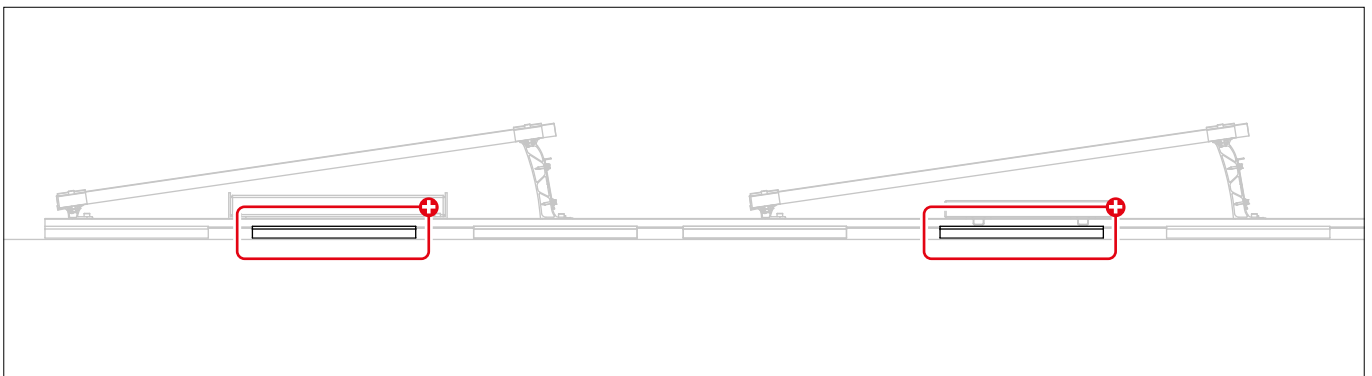

## Dome 6 Classic LS

- The additional Mat S must be added for all rails.
- For D-Dome 6 Classic LS, one Mat S is added under each Peak and SD - not at rail ends.
- For S-Dome 6 Classic LS, an additional Mat S is added between each Peak and SD.

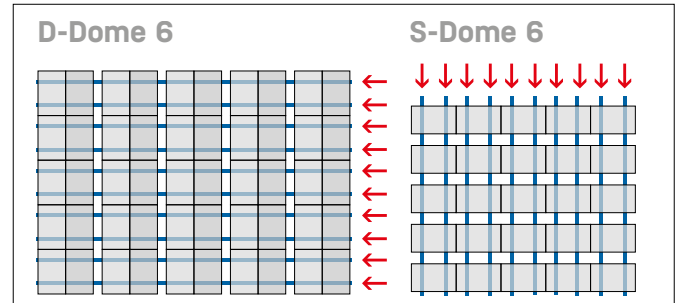

Additional Mat S are placed under the rails (blue) throughout the entire module block.

### D-Dome 6 Classic LS

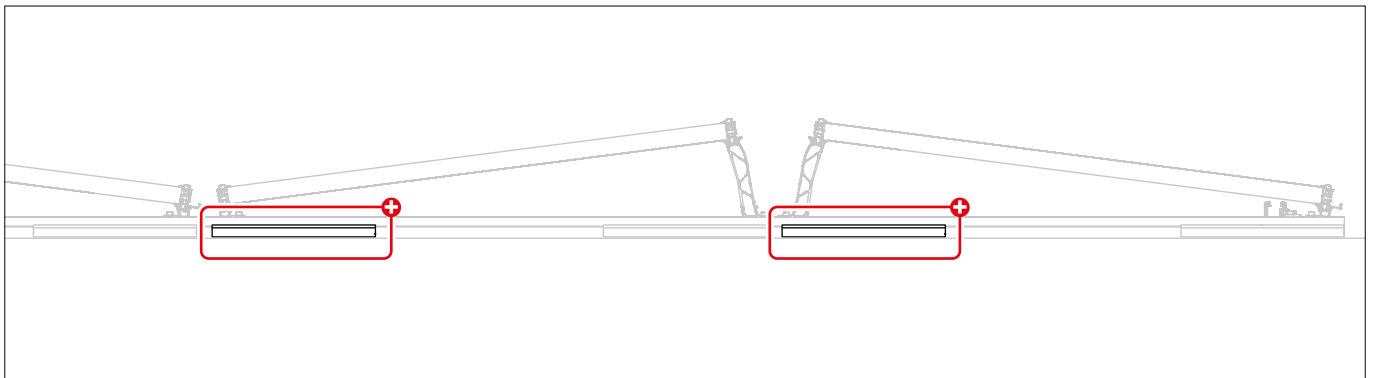

### S-Dome 6 Classic LS

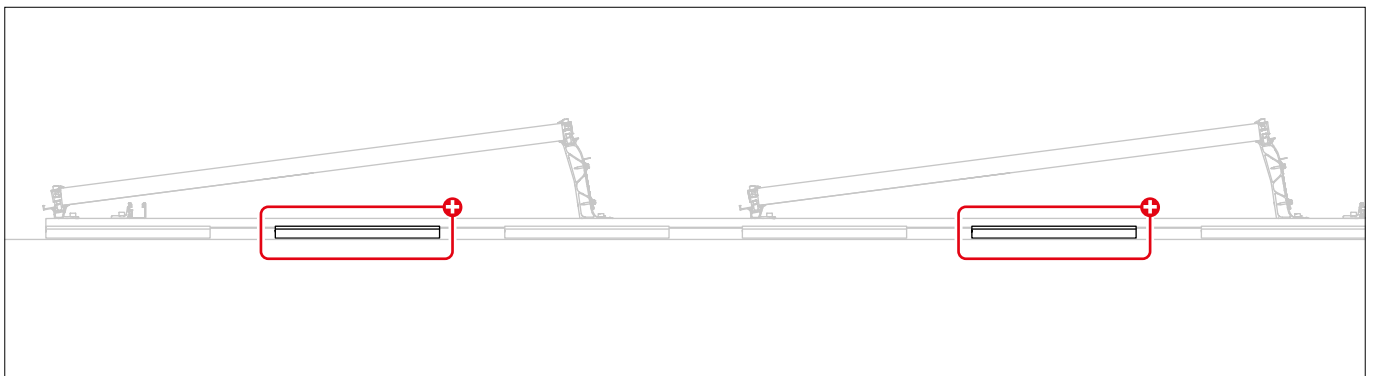

## Dome Zero

- The additional Mat S only needs to be added to the inner rails. See red areas in the illustration on the right.
- Under the Dome Zero Peaks, an additional Mat S is added centered to the existing Mat S - not at rail ends.

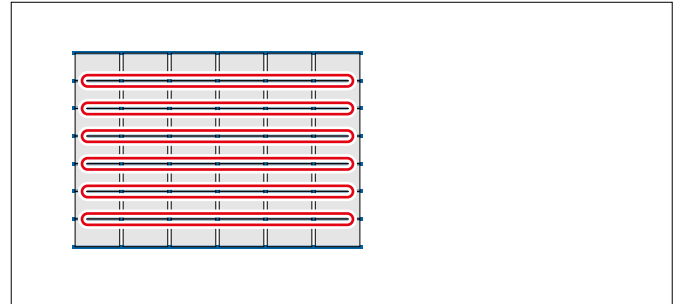

Placement areas in the module block under inner rails (blue)

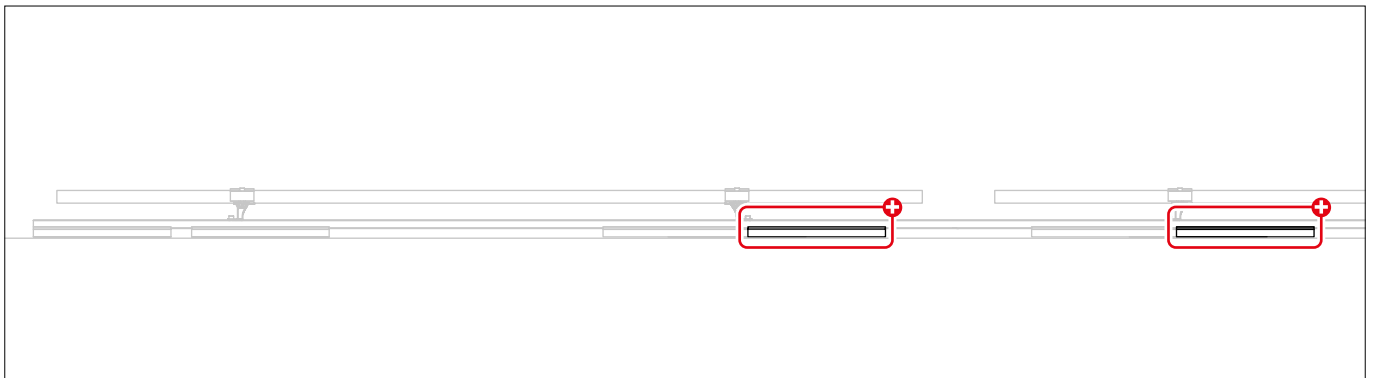

# Optimisation of load distribution

## Enlargement of the contact surface with LoadSolver

- Solution for special projects with soft thermal insulation and a wide range of customisation options
- Significant increase in the contact area and placement according to ballast centres of gravity possible
- Narrower distribution grid and substantial larger contact area possible
- Available as a project item with manual installation

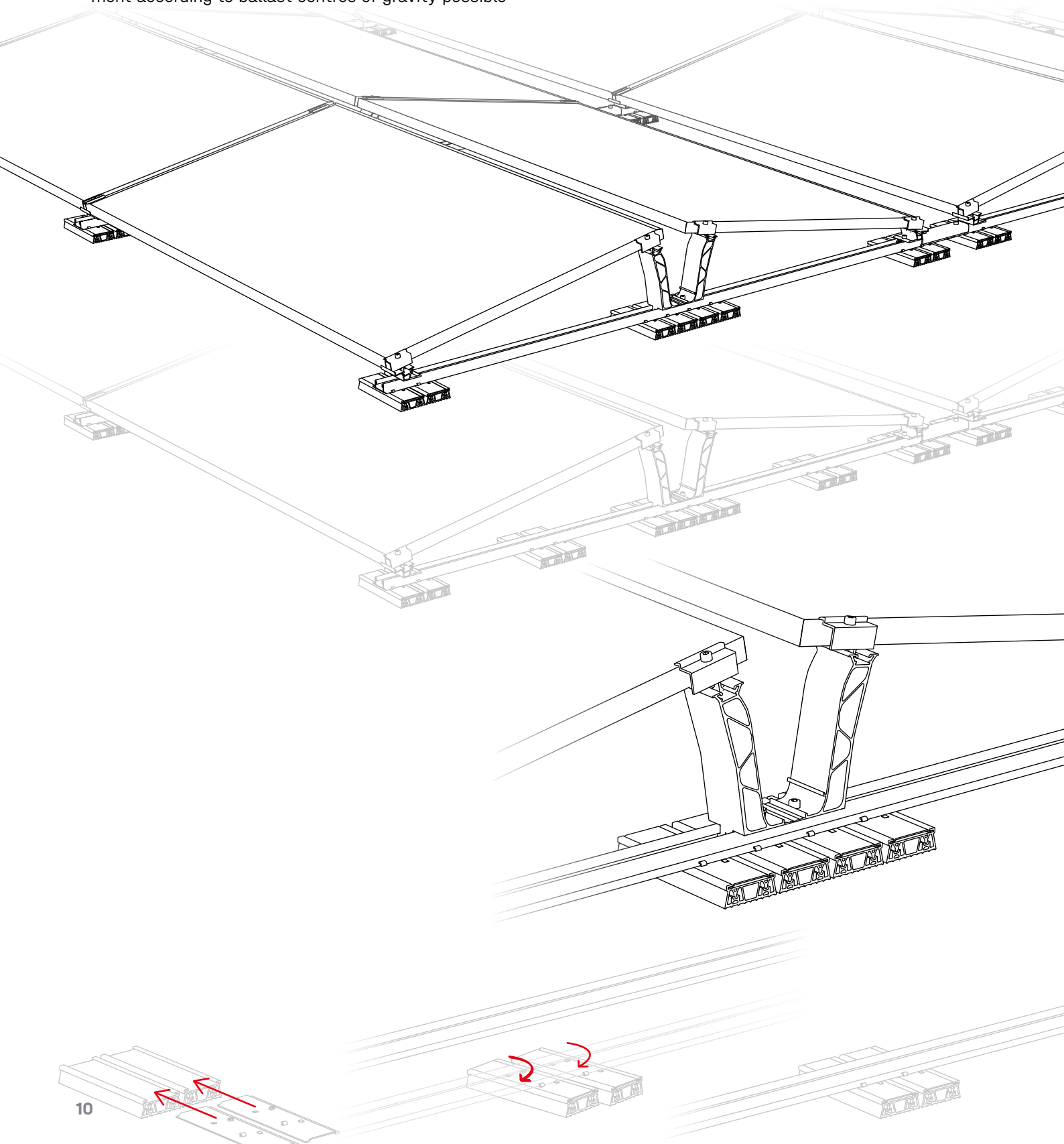





# Connecting Strength

## Thank you for choosing a K2 mounting system.

Mounting systems from K2 Systems are quick and easy to install. We hope these instructions have helped. Please contact us with any questions or suggestions for improvement. Our contact data:

- [k2-systems.com/en/contact](https://k2-systems.com/en/contact)
- **Service Hotline: +49 (0)7159 42059-0**

Our General Terms of Business apply. Please refer:  
[k2-systems.com](https://k2-systems.com)

**K2 Systems GmbH**  
Haldenstraße 1 · 71272 Renningen · Germany  
+49 (0) 7159 - 42059 - 0 · [info@k2-systems.com](mailto:info@k2-systems.com) · [k2-systems.com](https://k2-systems.com)

Load distribution flat roof EN V1 | 0626 · Subject to change · Product illustrations are exemplary and may differ from the original.